

---

• •

*Возникновение и развитие*  
допсихических,  
психических  
и  
социальных  
форм регуляции поведения  
\* \* \*  
*организма, субъекта, личности*

159.9:316.6

88

67

( )

:

· ·  
· ·

67

· ·

,

185 .: . - : - " - -XXI ", 2010. -

ISBN 978-5-91838-026-0

,

,

,

,

.

-

,

,

,

,

159.9:316.6

88

ISBN 978-5-91838-026-0

© . ., 2010

©

, 2010

©

" - -XXI ", 2010

	.....	5
<b>1.</b>		
	.....	10
1.1.		10
1.2.	.....	15
1.3.	.....	20
1.4.	.....	24
1.5.	-	
	.....	26
1.6.	-	
	.....	30
1.7.	.....	36
1.7.1.		
	.....	36
1.7.2.		40
1.8.	..	44
1.9.		
	.....	49
<b>2.</b>		
	.....	54
2.1.		
	.....	54
2.2.		
	.....	61
2.3.		68
2.4.	-	
	.....	74
2.5.	-	
	.....	78
2.6.	.....	80

<b>3.</b>	.....	94
3.1.	.....	94
3.2.	.....	107
3.3.		
	- .....	117
3.3.1.	..	117
3.3.2.		
	.....	120
3.3.3.		
	.....	127
3.3.4.	,	
	.....	138
3.4.	.....	143
3.5.		
	.....	148
3.6.		
	.....	152
3.7.	...	154
	.....	169
	.....	174



, . , -  
 ? , - .  
 . . , " , -  
 ' " [103, . 10]. . . , " -  
 , " [116,  
 . 72].  
 ,  
 ( ),  
 . " -  
 " , -  
 " " " " " " -  
 " , " , " , -  
 ,  
 . , -  
 , , , , , " -  
 " " " " " " , -  
 " " " " " " ,  
 , " " " ,  
 , , , , , " -  
 , " " " , -  
 " " " " " " " " , -  
 . . , " ...  
 : - - ( )"  
 [117, . 87]. , " " , -  
 , , , ,

[127, . 104].

" [3, . 52].

" [42, . 11].

[Chalmers], -

" [138, . xi].

" [108, . 102].

. 141]. : "... " [79, -

" [ ].  
" , " -  
" , . . . " -  
( ) « » , -  
 . . . , -  
 . . . « -  
 » , ,

. 192]. " [83, -

, " " " " " . " ,  
 , " - -  
 . . . [ , .205]. " " " " -  
 , - -  
 , , " " , -  
 " " -  
 , . -  
 , . -  
 ? , -  
 -  
 ? , -  
 , -  
 , , , -  
 , , , -  
 . . . , -  
 , " , -  
 , " -



[3, . 49].

,  
?

?

\* \* \*

2010 .

1.1.

, -  
, , -  
, " " [63]. -  
, " " -  
, " " -  
, , -  
, , -  
, " " -  
, " " -  
, , -  
[77]. , -  
, , -  
, , -  
, , -  
, " -  
, , -  
" [77, .144]. , " -  
-  
-

, " [ ]. ,  
 , , " " [ ].  
 . . . -  
 , . -  
 , , ' -  
 , , , . -  
 , , , -  
 , , , -  
 , , , -  
 , , , -

. 1.

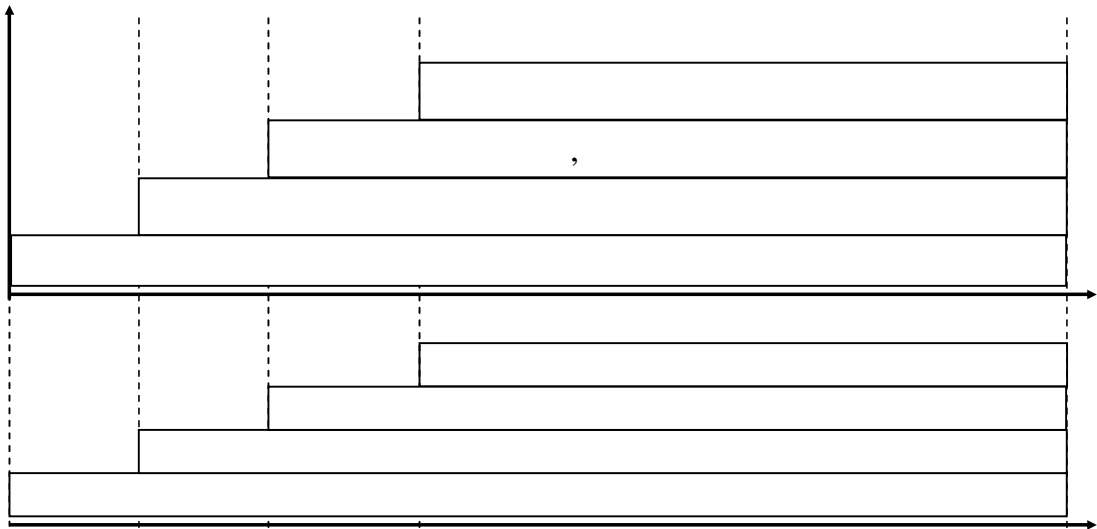

. 1.

, ,  
 .  
 , . . . , , , , -  
 , , , , -  
 " , , -  
 , , , -

" [77, . 145].

. . .

-

,

.

,

,

.

,

?

-

"

"

"

"?

. . .

,

,

,

"

"

,

-

.

,

. . .

,

-

"

,

,

" [77, c. 145].

,

,

,

. . . .

,

,

"

...

,

—

,

-

,

. . . .

, —

. . .

, —

,

...

,

" [49, . 166-167].

-

. . .

.

,

-

,

"

"."

,

-

, —

. . .

, —

,

" [3, . 5].

-

,

,

. . .

,

.

" [77, . 159].

,  
 ?".  
 ."  
 , — . . , — :  
 , -  
 " [18,  
 . 139].  
 , , -  
 , . . -  
 , , , -  
 . . , . -  
 . . . . -  
 , , -  
 , . . -  
 , , . -  
 . . . -  
 , . . -  
 " : " ... , . . -  
 , , -  
 " [112, . 37].  
 " — " -  
 . . [126, 127], . . [121], . . -  
 [30, 33], . . [44] -  
 . . . , " -  
 , -  
 , , , -  
 " [127, . 104].



" [24, . 23].

. 29].

"

" [87, . 8].

: — ( )



,  
 .  
 ,  
 ,  
 ,  
 .  
 ,  
 ,  
 .  
 ( ), ( ) ( ).  
 . . " .  
 , , — . . , —  
 ...  
 , " [20, . 17].  
 . . , " "  
 , , , —  
 , , , —  
 " " , ,  
 , —  
 , ( ) —  
 . " , —  
 , , " —  
 . . [20, . 109].  
 , —  
 , —  
 .

. . , , -  
, ,  
, ,  
• ,  
.  
.  
,  
- , -  
, , . -  
, -  
- , -  
• ,  
.  
.  
, ,  
- , -  
,  
,  
, .  
( ) -  
( ) .  
,  
,  
, ,  
., - ,  
, ,  
, -  
.,  
-  
.

,  
 .  
 ,  
 ,  
 ,  
 .  
 ,  
 ,  
 .  
 ,  
 ,  
 .  
 ,  
 ,  
 .  
 .  
 .  
 " " ,  
 :  
 ,  
 , " "

. 2.

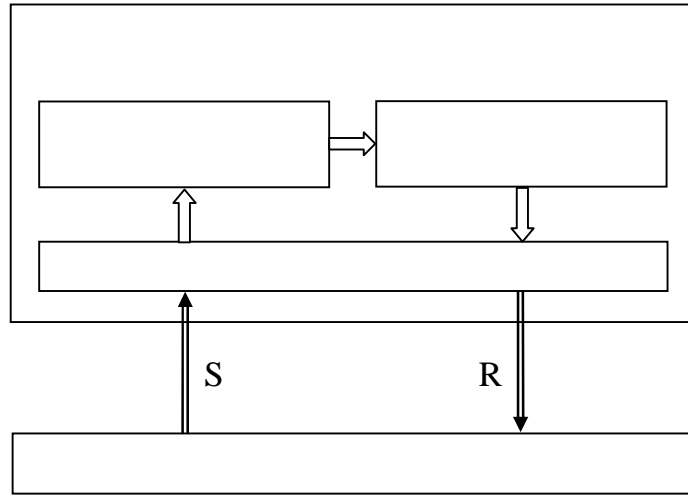

. 2.

**1.3.**

, , , -  
 ( ), -  
 ( , ) [61]. -  
 , -  
 . -  
 , -  
 , -  
 , -  
 ( , ) -  
 ). -  
 . -  
 , -



" " . ,  
 . -  
 : ,  
 ) ,  
 , ( , -  
 , " " ); -  
 ) , -  
 , , , -  
 . ( -  
 , -  
 ). -  
 , -  
 , -  
 , -  
 . , -  
 , -  
 . , -  
 , -  
 , -  
 , -  
 . , -  
 . -  
 , -  
 -

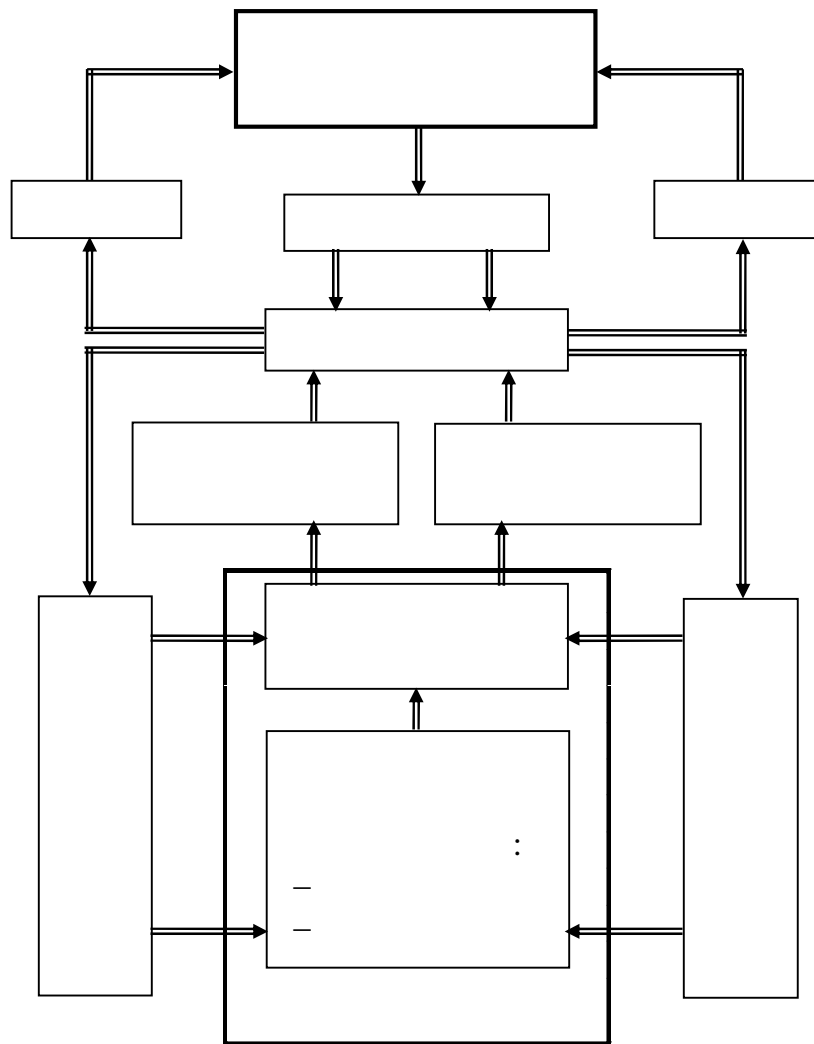

.3.

.3.

1.4.

... " [13, . 388].

S R, S-

, R-

" .  
R,

V R, V-





, -  
 ,  
 " " .  
 ,  
 , , .  
 ,  
 .  
 ,  
 " " .  
 , ,  
 ,  
 ) ( .  
 ) ( .

**1.5.**

, -  
 " " .  
 , - . .  
 , - . . .  
 " [23, . 8].  
 , " -  
 - - , -

" [108, . 125].

, . . ,

[83].

,

,

,

,

,

.

[109].

,

.

,

,

,

.

,

.

,

,

.

,

,

,

,

.

,

.4.

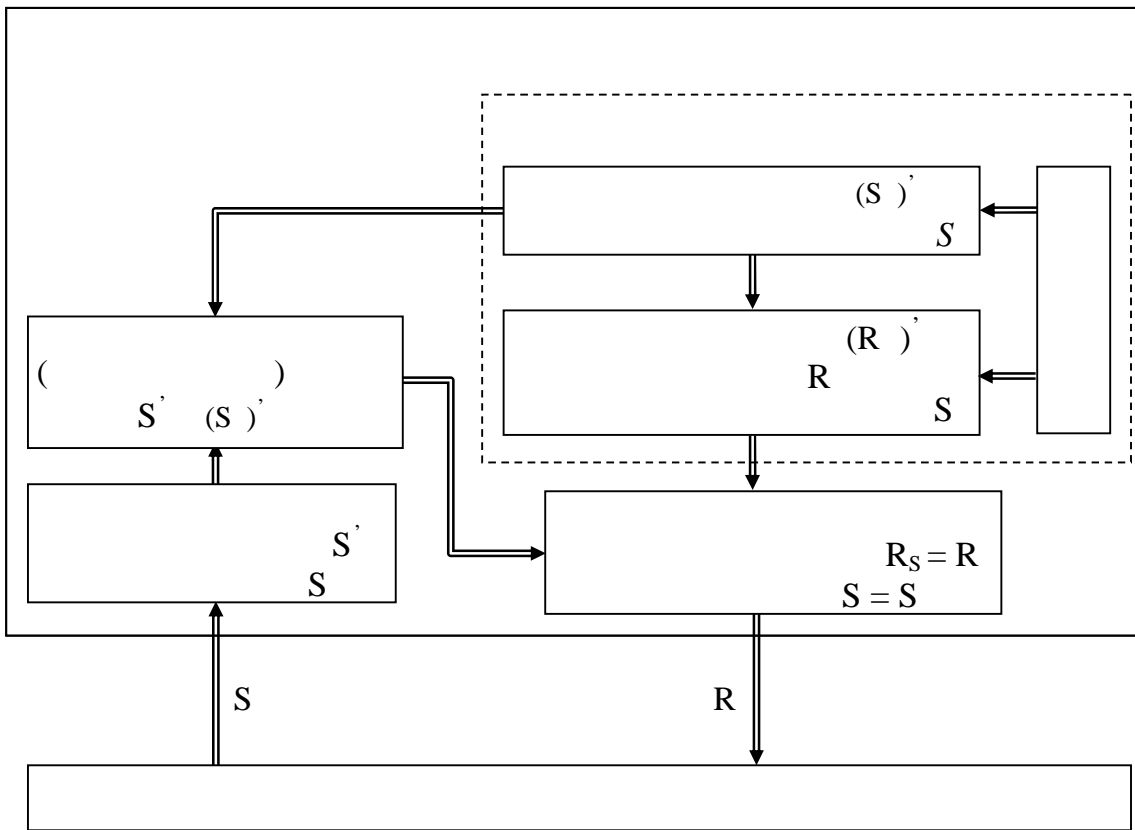

. 4.

S,

S,

R<sub>S</sub>,

S ⇒ R .

... [77].

1.6.

( ) ... [77, . 173].

[83].

" [77, .173].

" [ , . 149]. , "

[ , . 151].

[77, . 173]. . .

" [83].

[112], [126], . . .

[30], . . . [44] ? [127, . 104].



. . . , " " -  
 ? -  
 , -  
 , -  
 . -  
 , -  
 . . . -  
 - -  
 , , - -  
 , -  
 , -  
 , -  
 . -  
 . " , - . . -  
 , -  
 , , - -  
 , -  
 , -  
 . . . , , -  
 " [77,

. 173].



[74]. . . ,

. . . -

-

, , . . -

, " , -

, -

. , -

, -

, , -

" [35, .22]. -

-

. . . [130], . . .

[72], . . . [111].

-

, , - , , -

-

, -

.

,

,

, -

.5.

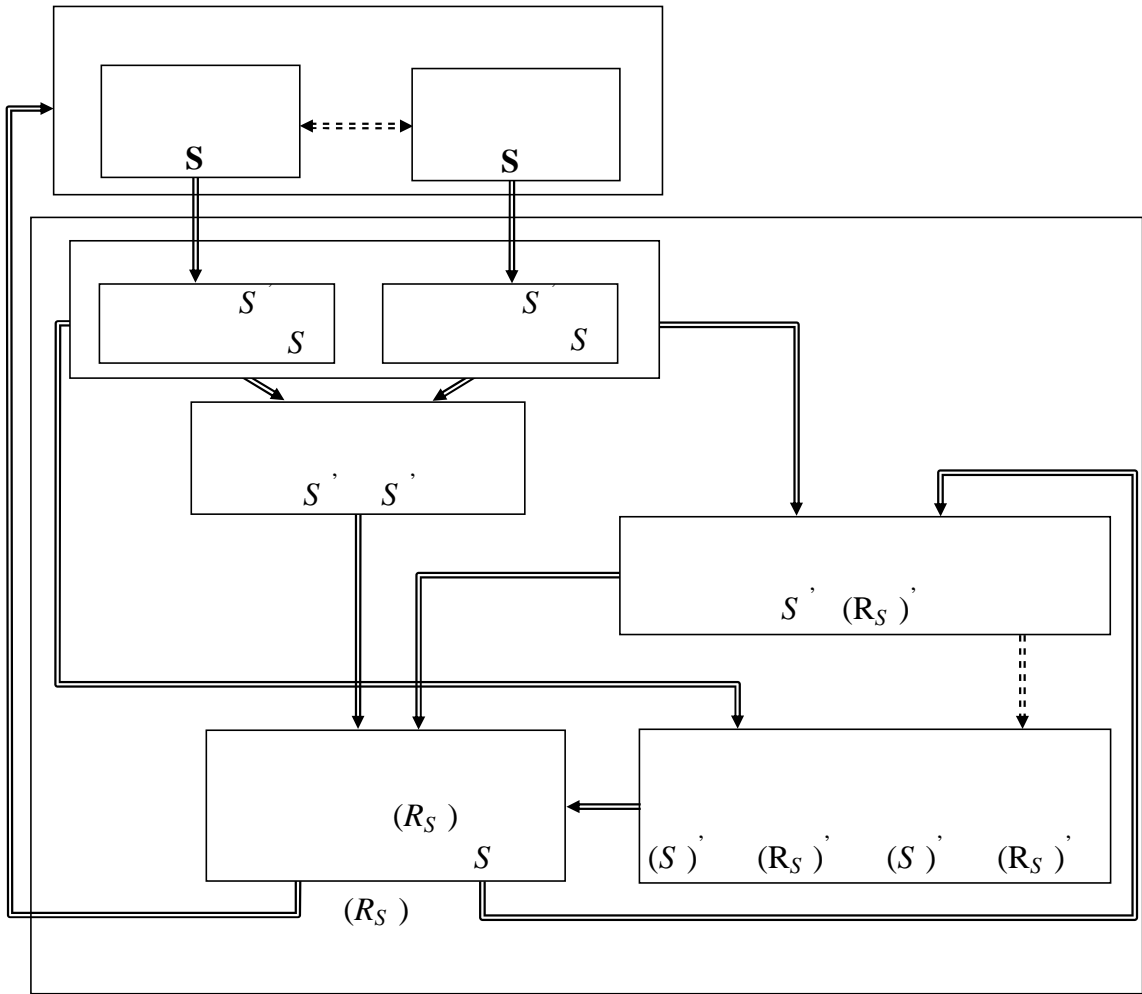

. 5.

-

1.7.

1.7.1.

, -  
 , . . , , -  
 , , -  
 . , , -  
 , , -  
 , , -  
 , , -  
 , , -  
 , , -

...

[109]

...

[129].

)

$S'$

$S$

$S$

$S'$

( . 1.2),

, , -  
 , -  
 , , -  
 . -  
 , -  
 [76]. -  
 , -  
 , , , -  
 , , -  
 , . , -  
 , , -  
 , ( ) -  
 , -  
 , -  
 [114]. , -  
 , -  
 , . -  
 " , , " ( -  
 [28], ( -  
 , ) -  
 , -  
 [123]. , -  
 , -  
 , -  
 , , , -  
 : -  
 - - , -  
 , -  
 , -

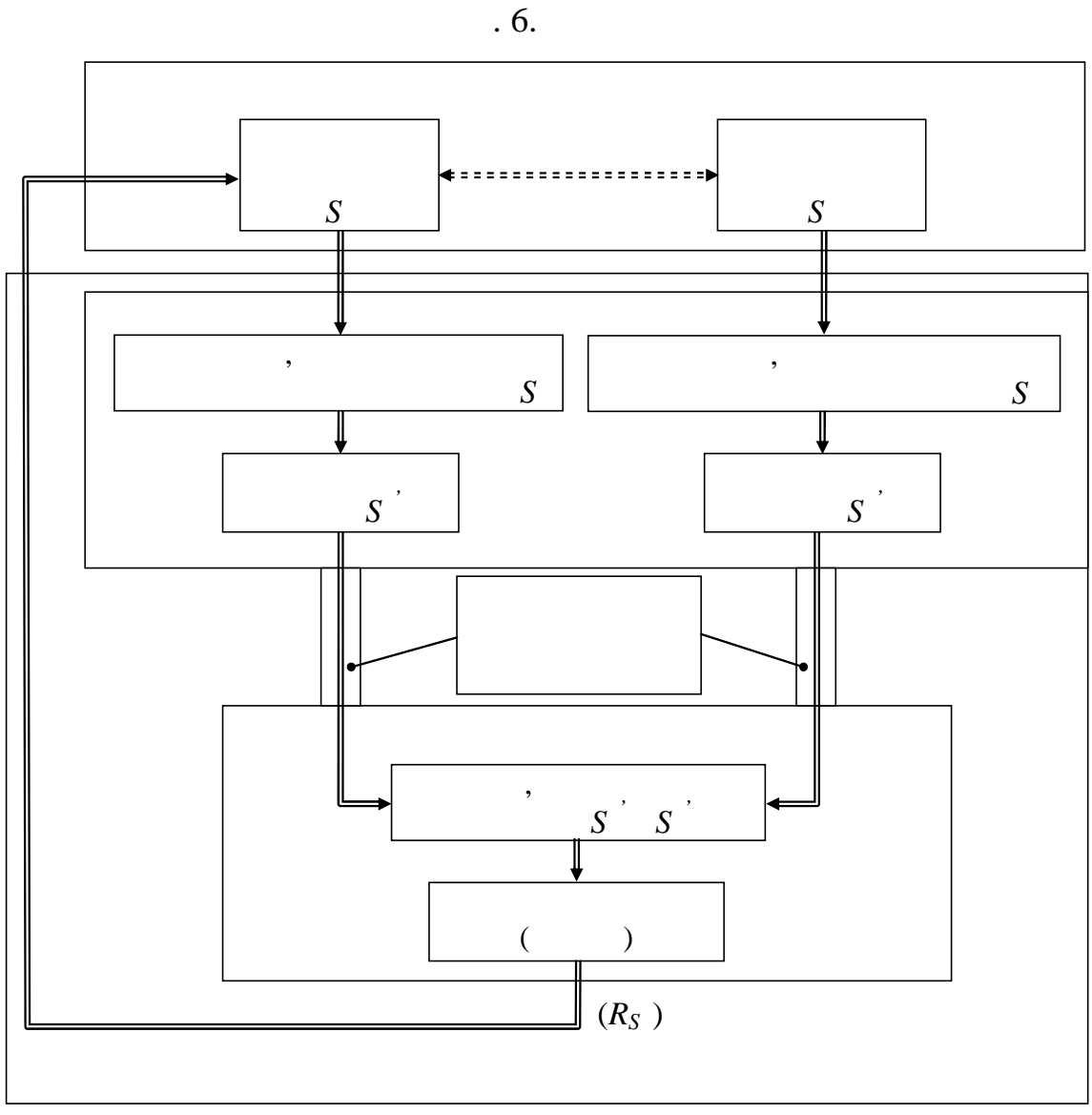

. 6.

### 1.7.2.

, ,  
, ,  
— ,  
.  
, ,  
.  
, .  
, .  
, ( )  
, ,  
, ,  
, ,  
, .  
.  
.  
.

[26].



, . , -  
 , . . , -  
 S S -  
 , , f f , -  
 , . , -  
 , -  
 S ' S ' f f -  
 S S . -  
 , -  
 , -  
 , -  
 S ' , -  
 , -  
 S ' . -  
 " " . -  
 [141], -  
 , , " " , -  
 , , -  
 , , -  
 , , .7. -

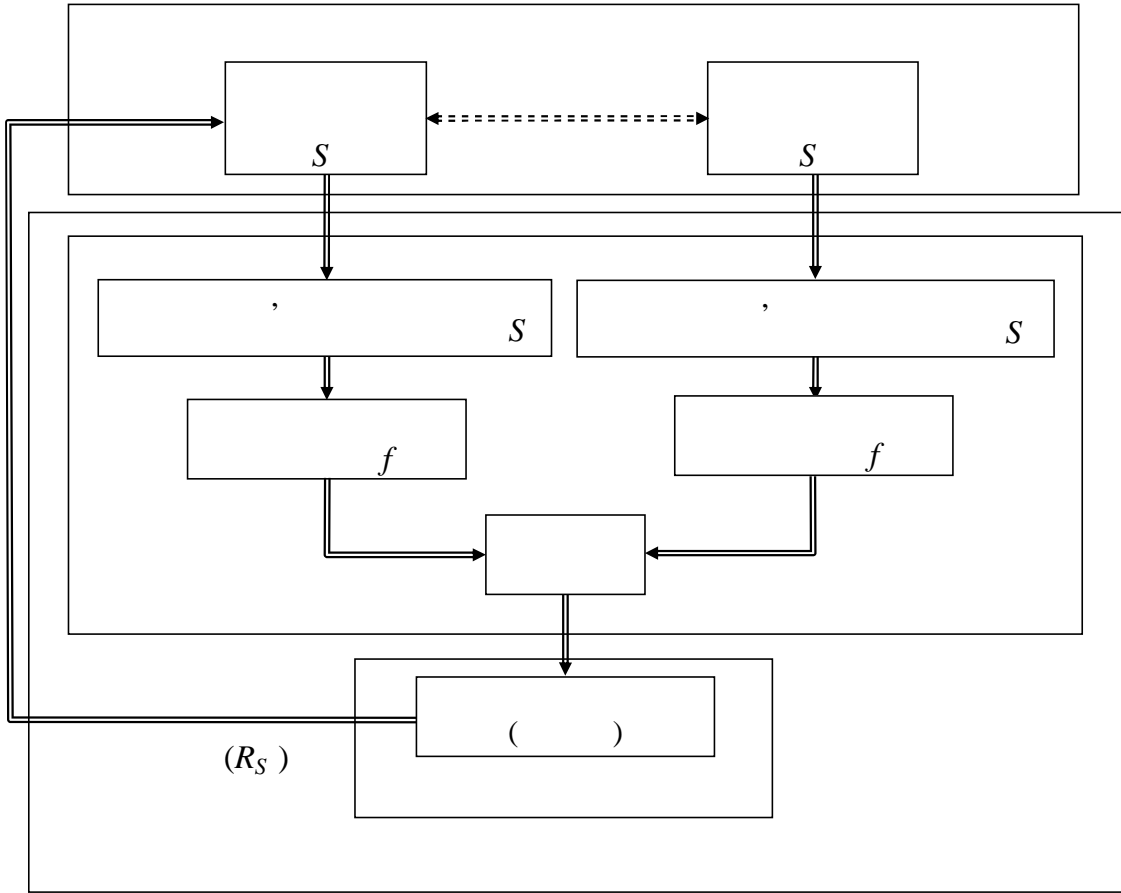

. 7.

( -  
) -

.

, , -

,

- -

.

, -

,

.

,

, ,

. , , -  
 , , -  
 . - (  $R_S$  ) , -  
 .7, -  
 , -  
 - , -  
 . ( , ) , -  
 , , -  
 , " " . -  
 , [96]. -  
 , -  
 , -  
 . -  
 , -  
 , -  
 , -  
 , -  
 , -  
 , -  
 . , -  
 , -  
 , -  
 , -  
 . , -  
 , -  
 , -  
 , -  
 . , -  
 , -  
 , -  
 . , -

[7, 55].

1.8.

$$R_S = R_S .$$

,  
 ,  
 . . . [9],  
 ,  
 " " ,  
 " " .  
 , - -  
 , ,  
 " " ,  
 " " .  
 , ,  
 .  
 " " " ( . . .  
 [9]), " " ( . . . [115]) "  
 " ( . . . [5]) "  
 , " "  
 . ,  
 , .  
 ,  
 . ,  
 ,

, -  
 -  
 .  
 , , -  
 -  
 .  
 " " -  
 -  
 ,  
 " " [9].  
 . .  
 " " -  
 -  
 ,  
 " , " -  
 " ( . . 8).

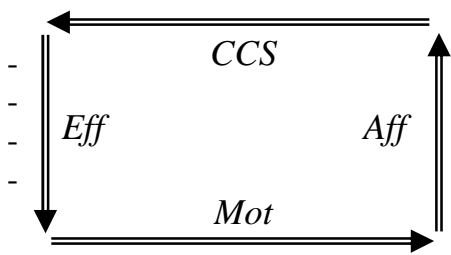

. 8.

. . .

" , — . . . , — - -  
,  
, -  
-

" [9, c. 31].

( , , ),

· , , -  
" " -  
· . . . , " -  
, -

" [9, . 32].

, , -  
· , -  
" " -  
" " -  
" " -

" , — . . . , — -  
, - ... -  
, ... -  
· -  
... , -  
, -  
, -  
, -

" [9, . 70].

.9.

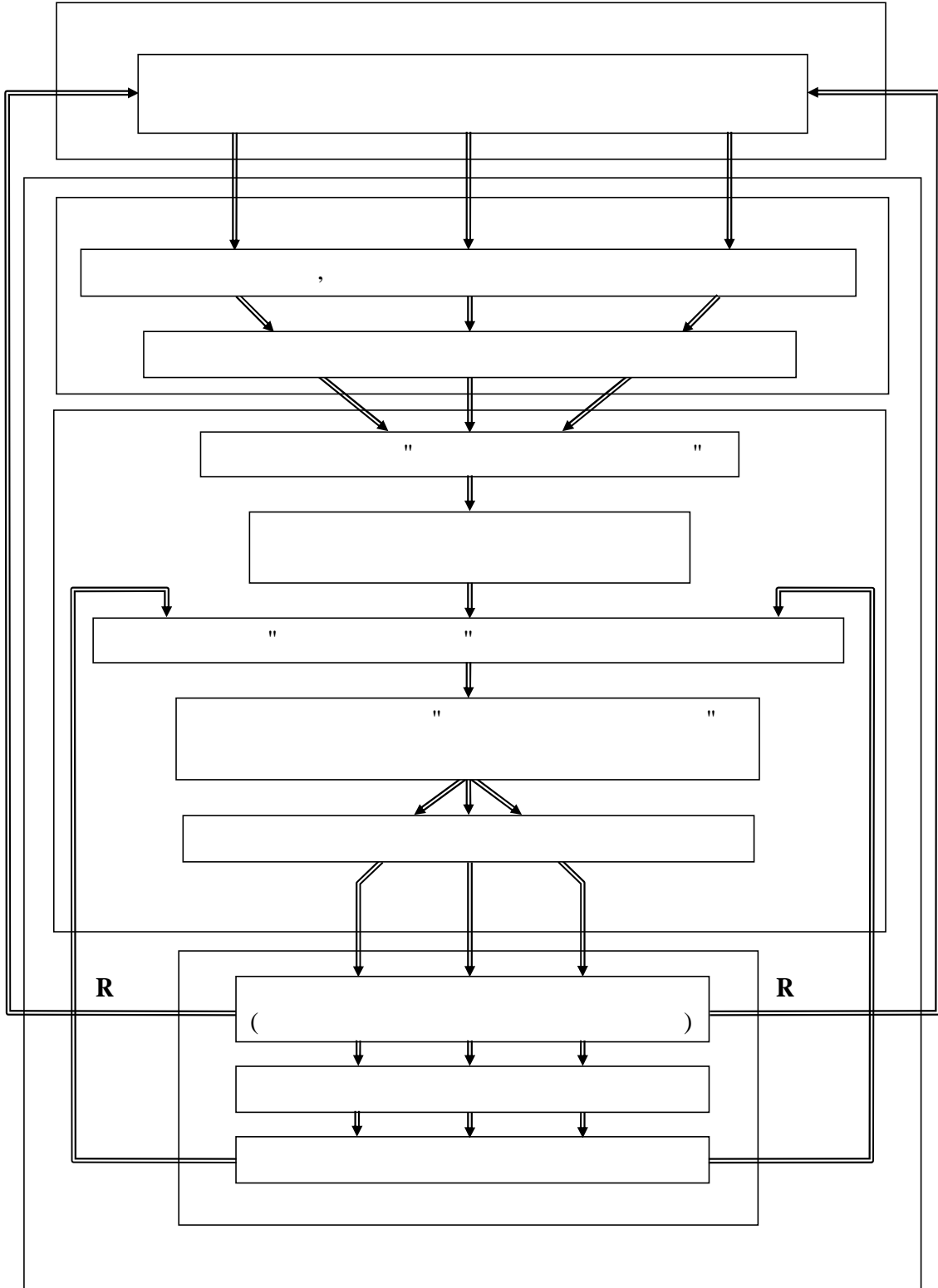

.9.





, ( -  
 ) ( ). -  
 . -  
 , -  
 , -  
 . -  
 . -  
 , -  
 " " " " " -  
 " " " " -  
 , , -  
 ( -  
 ), -  
 . -  
 " , -  
 , -  
 , -  
 ... -  
 ; -  
 " [9, .65]. -  
 . -  
 , -  
 -  
 . -  
 , -  
 . -  
 , -  
 . -



,  
 -  
 ,  
 -  
 ,  
 -  
 ,  
 -  
 ,  
 -  
 (       )  
 -  
 "       "  
 ,  
 -  
 :       ⇒       ⇒  
 ⇒       ,  
 -  
 ⇒       ⇒       ⇒  
 .  
 ,       ,       :  
 ⇒       ⇒       ⇒  
 -  
 ,  
 ,  
 :  
 ⇒       ⇒       ⇒  
 -  
 ,  
 :  
 ⇒       ⇒       ⇒  
 -  
 ,  
 (       )  
 -  
 (       )  
 -  
 .

, -  
-

, . 10.

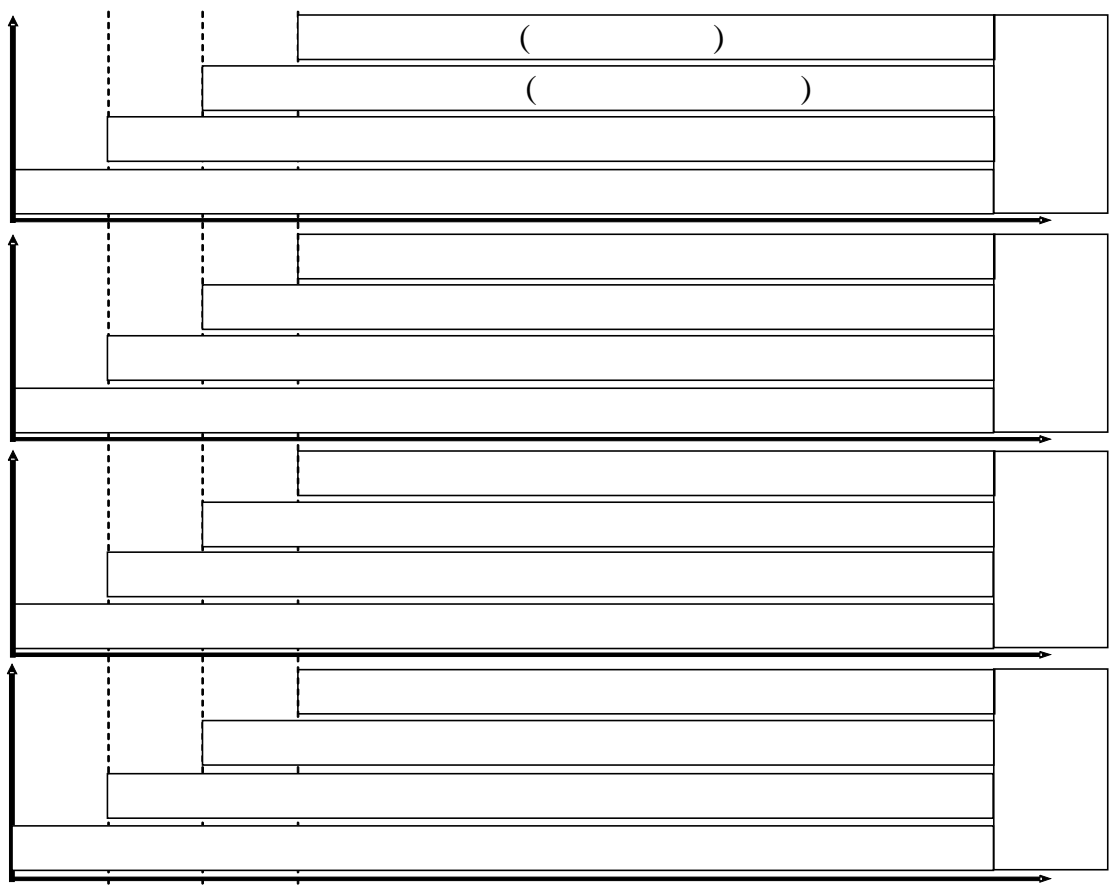

. 10. -  
, ,  
.

2.1.

$$S \Rightarrow R.$$

[59, 61].

[63, 65].

" "

*t*

, = + .

" "

" "

?

" "

[65],

" "

[102].

"

"\*

$$- = - \tag{1}$$

(1)

$$= + ( - ) \tag{2}$$

(2)

\*

" [79, . 432].

, ( ) -  
 " ( )  
 " ( ),  
 ' = ' + ( ' - ' ).  
 " "  
 " "  
 [44]  
 " [44, . 205].



,  
 ,  
 ,  
 . [142],  
 [31-33, 44] . "  
 , -  
 . . . , -  
 ,  
 ,  
 « »" [33, . 10].  
 , , ,  
 , , ,  
 , . ,  
 , . . . " "  
 , " "  
 . . . " , - . . . , -  
 -  
 resp. .  
 ,  
 ,  
 " [10, . 15]. [57],  
 , " "  
 . . .  
 : 1)  
 2)  
 ,

. . . , . . . " " " -  
 " , -  
 . -  
 . -  
 [4]. , , . . . -  
 " " . [55] , , -  
 , . . -  
 , , -  
 " " , . . -  
 . , -  
 , .  
 ( ) .  
 , ,  $t = t_1$   
 1. 1  
 " " ,  
 , . -  
 , , -  
 , . -  
 , ,  
 , .  
 , 1.

, 1, -  
 ,  $R$ , 1. -  
 , 1 1 -  
 $R$   $t$ , -  
 1 , -  
 - 2. -  
 , 1, -  
 2 . " " ( -  
 2) , -  
 , 2, 1. -  
 2. , -  
 , ( -  
 1), -  
 ( 2). , -  
 , , -  
 . -  
 , -  
 , , , , -  
 , , , . -  
 , -  
 , , -

( , - ) -  
 ) ( ) -  
 . . .  
 , 2 , 2 , ,  
 , 1 , 1 ,  
 " " , , , 0 ,  
 0 . 2 -  

$$x_2' = x_1' + (x_1' - x_0')$$
 (3)

. 11.

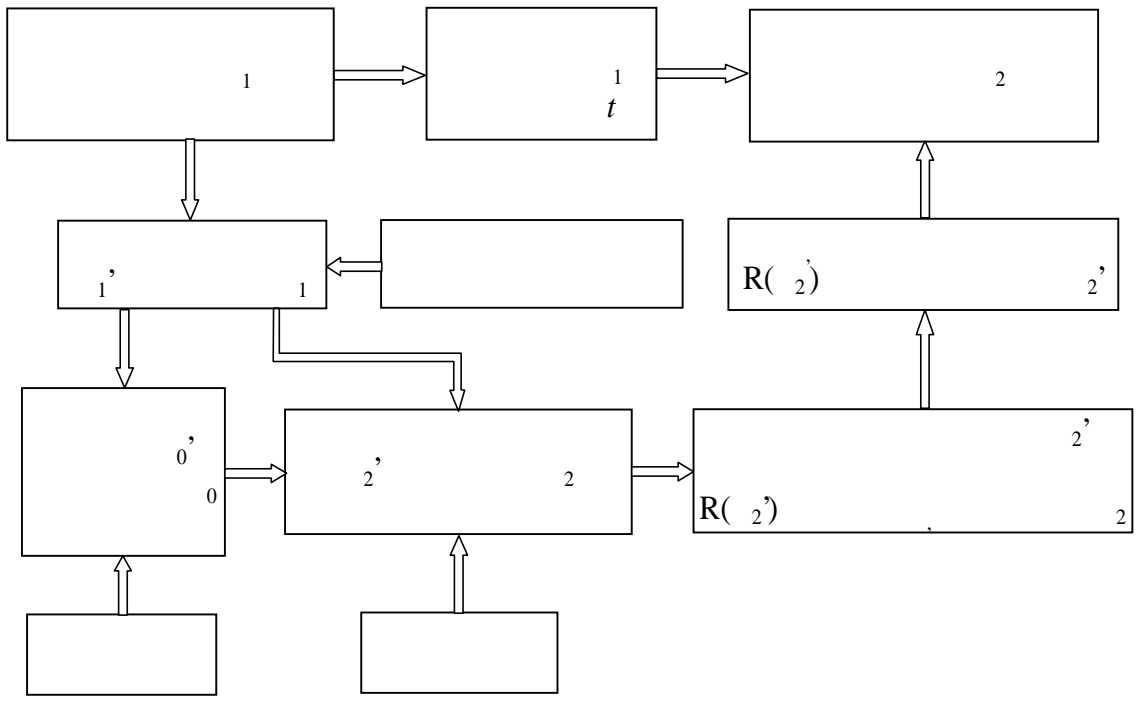

. 11.

. 12.

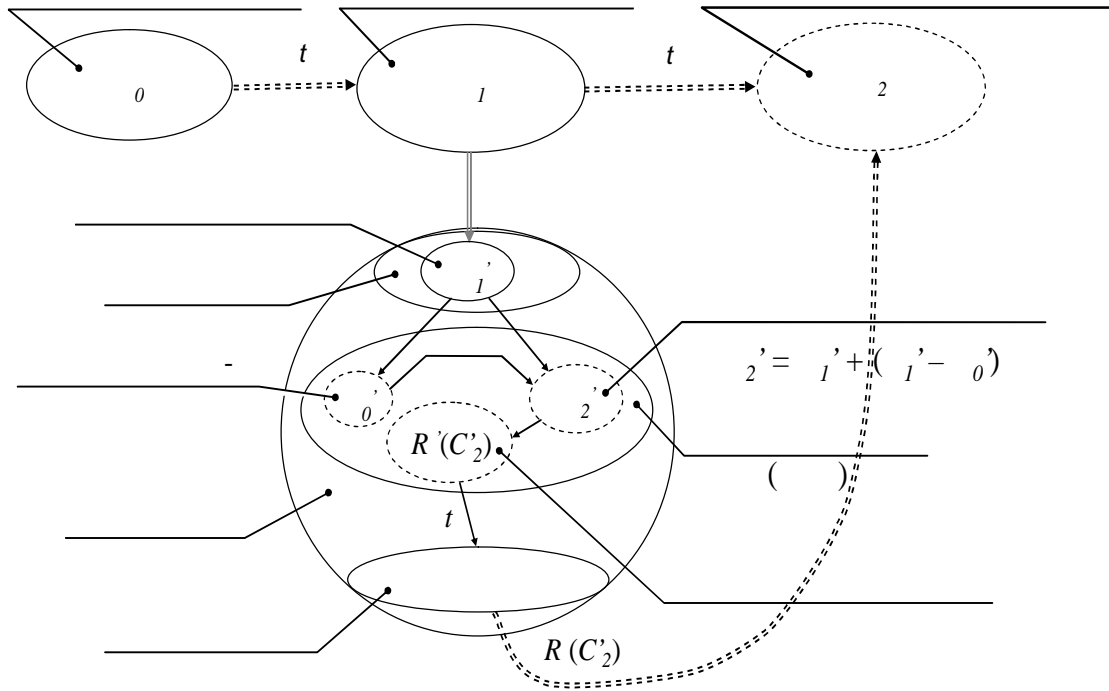

. 12.

## 2.2.

... , " , " [77, . 146]. , " [15, . 76].

, , -  
 , , -  
 , , -  
 , , .  
 , . . ,  
 - ,  
 : " ,  
 , « - » -  
 - . -  
 , , , -  
 , -  
 . ,  
 " [77, . 176]. -  
 , -  
 " , " . -  
 - , , . -  
 -  
 . . " " -  
 : " , ( )  
 , " .  
 , ,  
 . . , - , ,  
 , , ,  
 ? -  
 . , " -  
 . . , - , -  
 - , -  
 " [108,

c. 310]. "

, —

. . .

, —

-

,

,

,

-

,

...

,

" [108, . 309].

-

. . .

-

!

,

,

-

. . .

-

,

,

-

,

.

,

-

,

,

,

,

.

-

. . .

. "

,

-

, —

. . .

, —

,

,

-

.

-

,

-

,

,

-

-

,

" [77, . 183].

-

,

-

[26, 103].

$$f = a * \log J + b \tag{4}$$

:f-  
J-  
a b-

( )



... " ... [26, . 227].

... " ... [77, . 192].

$$(4) \quad J_1$$

$$f_2 = a \cdot \log J_2 + b.$$

$f_2$

$J$

$f.$

$$(5) \quad f_2 = f_1 + f \quad (5)$$

$f_1,$

$J_1,$

$f.$

( t )

:

$$(J' - J) (J - J') = J \quad (6)$$

$$f = f - f \quad (7)$$

$$f \quad (5)$$

$$f_1 = f, f_2 = f, f' = f + (f - f') \quad (8)$$

(8),

$$J' = J + (J' - J) \quad (9)$$

(9) , ?

(9) ,

( ) J

f J'

f ,

$J$  ,  
 $t$  ,  
 $f$  . ,  $J$  . . -  
" " ,  
 $f$  , -  
 $t$  . , -  
" " ,  
 $J'$  , , ,  
" " ,  $J'$  . . -  
- . -  
, . -  
, ,  
. -  
 $f$  -  
 $f$  .  $f$  , (7).  
, , -  
 $f$   $f$  ,  
.

$f$  . ,

$J'$  .  
 $J$  .

. 13.

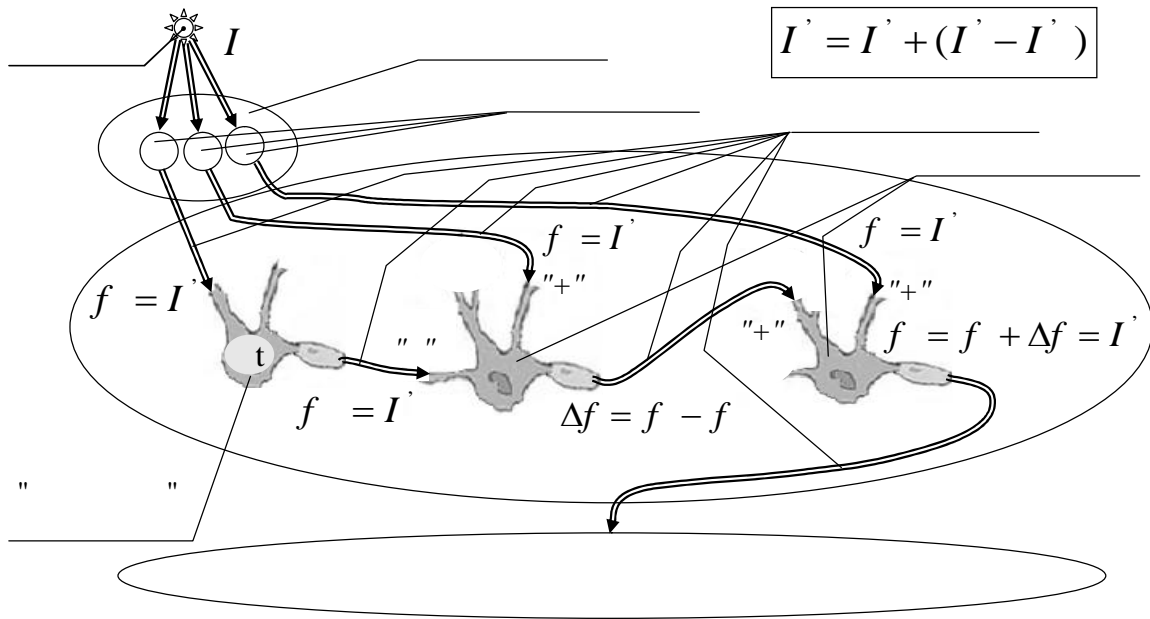

. 13.

2.3.

( )

[68,

70],



, , -  
 : " ( -  
) , -  
 " [78, . 4].  
 , " -  
 , , -  
 " [80, . 483].  
 . . " ,  
 , , , :  
 " " [108,  
. 587].  
 . " " -  
 . . -  
 , , -  
 . , -  
 , . . " , -  
 ( ) ,  
 , " [108, . 587], , " -  
 , -  
 " [ ] . " -  
 " -  
 . -  
 " " .  
 , " " " -

" [128, . 8].

" [ . ].

" [25, . 211].

[22].

(affordance),

" [22, . 320].



. 14.

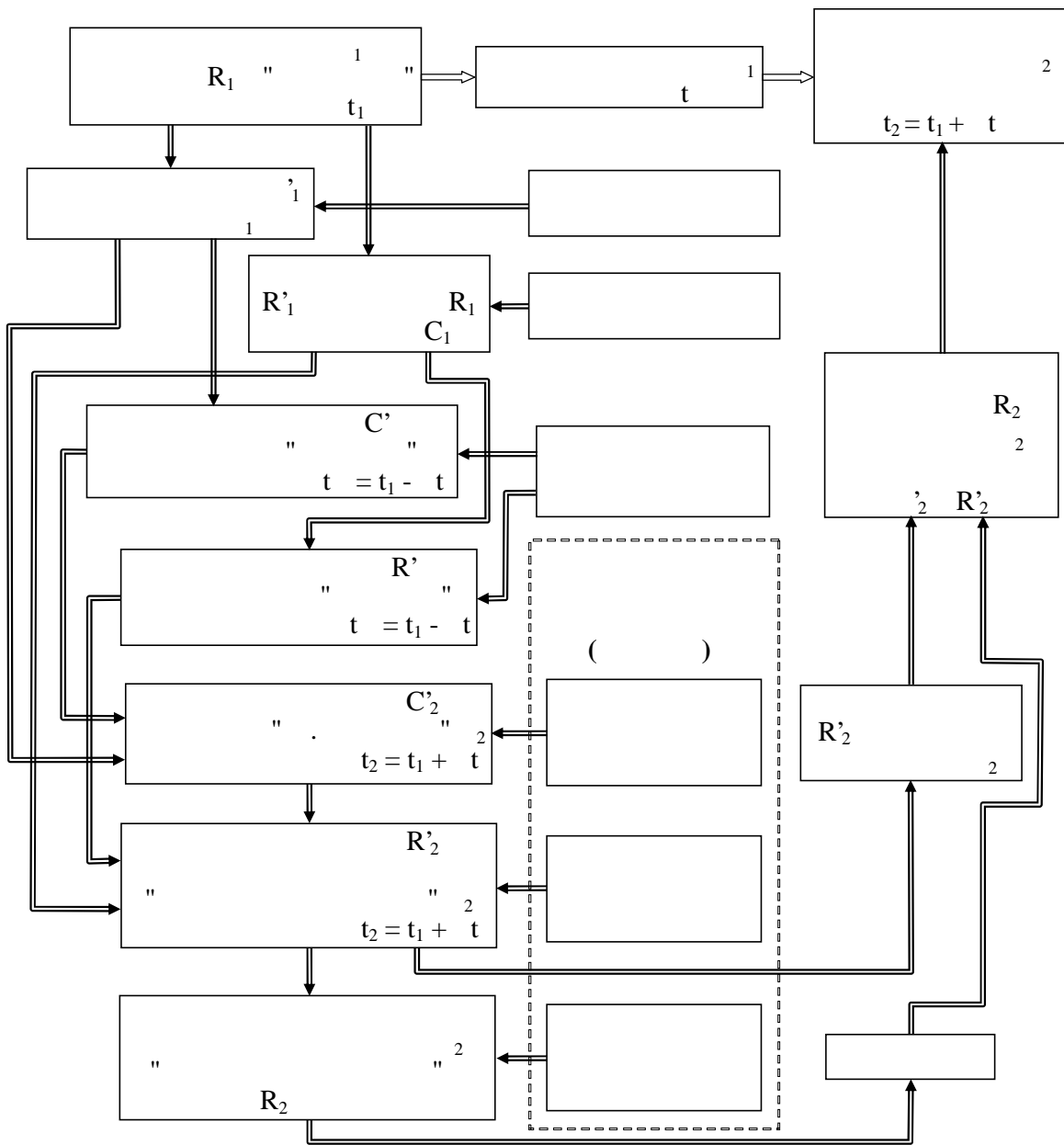

. 14.

( )

... [77], , ,  
 :  
 1) ;  
 2) ;  
 3) ;  
 4) .

" " , " " , -  
 " " , -  
 -

**2.4.** -

, -  
 , -  
 , .  
 -  
 . -  
 -  
 , -  
 . " ,  
 . . , " ,  
 , -  
 , -  
 " [125, . 63].  
 " " . -  
 , " -  
 ( - . . ) ( - . . ) , . .

) - - ( -  
- " -  
, - . . , -  
( -  
) . , , " [125, . 61].

, , -  
, -  
, -  
, -  
" , , " ,  
" " ,  
" . , , -  
" " -  
" ( , ) , -  
, " " [58].

" " . , -  
, -  
" " ( ) -  
" " -  
" [69]. , -  
, -  
.

,  
.  
,"  
-  
-  
-  
" [29, . 314].  
-  
(  
-  
- . .),  
-  
" [ . ].  
,  
,  
" " ,  
,  
" " " " " ( )  
" " .  
:  
) , -  
;  
)  
;  
) , -  
.  
-  
" "



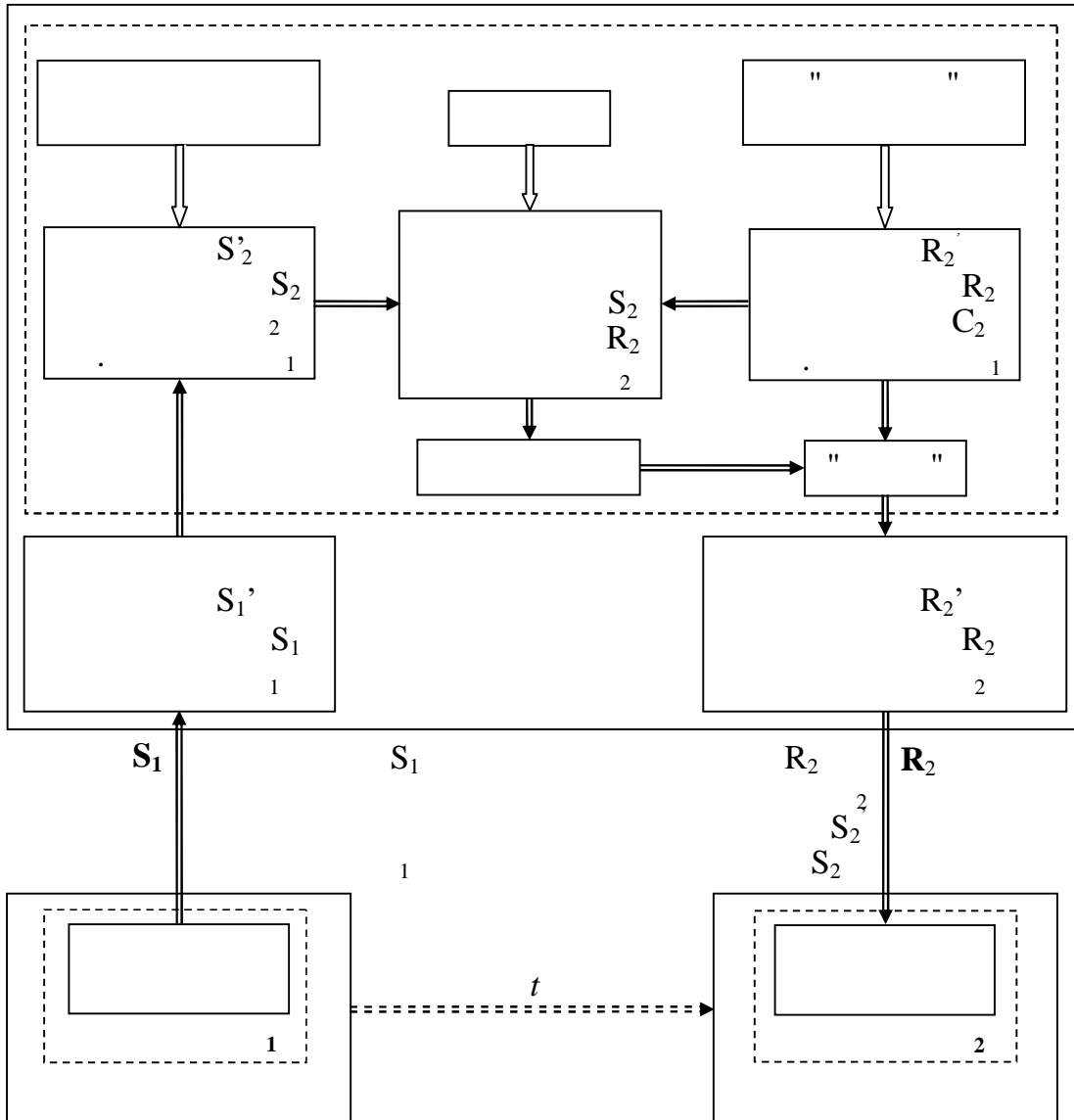

. 15.

" " ( , ) .

2.5.

-

" "

" "

,

,

,

,

,

[105].

,

,

,

,

1, 2, 3, 4 5,

"

"

$R_A$ .

$B$ ,

1= 1, 2= 2 3= 3,

"

"

( 4 5 )

$R_A$ ,

$$4^4 = 4 \quad 5^5 = 5 \cdot$$

## 2.6.

) ;  
) ;  
) " " .  
" " .  
, , , - ,  
, - ,  
" " " " .  
... , (" ")  
...  
...





,  
 . ,  
 ,  
 ,  
 .  
 .  
 , , ,  
 , , ,  
 ,  
 ,  
 - [85].  
 , " "  
 ( . . [96]), " " ( . [48]), "  
 " ( . [101]).  
 ,  
 ,  
 ,  
 : ,  
 ,  
 .  
 , ,  $D$ , 1,  
 .  
 ( 1), ,  
 1.  
 $R_A, R_B, R_C, R_D$  , , ,  $D$ ,

$R_{K_1}$ ,

$E$ ,

1 ( . . . 16).

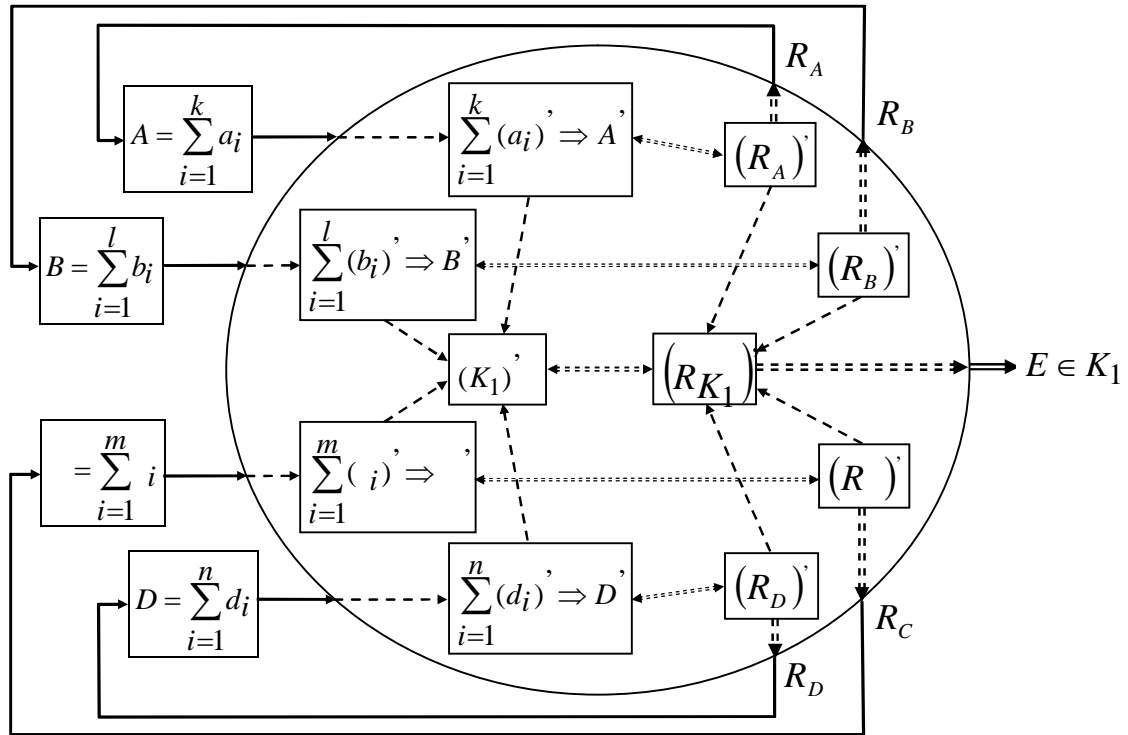

. 16.

$(K_1)'$

$A, B, C, D,$

1,

$(R_{K_1})'$

$(R_A)', (R_B)',$

$(R)'$ ,  $(R_D)'$

$R_A, R_B, R_C, R_D$

$A, B, C, D. ( E \in K_1$

1).

$(R_{K_1})'$

,

1.

...

-

[93]

-

...

...

[43].

-

(

).

-

-

.

,

$R_{K_1}$

,

1,

,

.

,

"

-

"

.

-

,

-

,

.

,

-

,

,

,

"

"

,

-

.

-

-

-

-

,

.

,

,

-

,

.

-

,

,

,

-

,

,

,

-

.

-

“ ” -  
, ,  
, .  
, .  
,  
.  
— ,  
.  
, -  
, -  
“ ”,  
.  
( , , ),  
.  
,  
, , “ ” -  
“ ” -  
“ ”,  
.  
: .  
“ ” -  
,  
“ [108, .317]. ” -  
.  
, -  
, -  
“ [118, .44].  
“ ” : “

[108, . 34].

" [79, . 50].

[14]

[67].

" "

-

,

, . . , ,

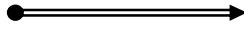

,

: " " —

,

-

;

" " —

-

.

—

,

,

-

—

,

,

.

-

,

,

,

-

,

.

,

,

,

:

,

-

.

,

,

,



,

: " " —

;

" " —

.

"

"

"

"

,

,

-

,

,

,

-

.

,

-

,

,

,

.

[67],

, ,

,

, ,

-

.

.

" "

-

,

,

"

"

"

-

"intellectus"

"

",

"

" , "

".

[60, 67]

-

,

-

,

-

,

,

-

"

"

,

. .

,

"

-

,

-

,

( )

" [23, . 178].

-

-

.

"

"

. .

.

"

-

" "

",

"

"

"

,

" [103, . 13].

,

,

-

,

,

-

,

,

-

.

,

,

-

,

"

",

-

,

"

".

-



( . [62, 67]),

" ", .  
,  
, , .  
, , -  
( -  
) , , ,  
.  
" " , .  
,  
" " , .  
, .

[48]

( )  
( ).  
.  
" ,  
" [48, . 247]. : "  
,  
, ,  
(  
- . .),  
,  
" [ ].



. . .  
" [77, .212].  
," -

" " ,  
,  
,  
,  
,  
( )

,

," " .  
,  
,  
,  
(  
) ,  
( " ) ,

( " ")

.

,

"

,

" "

,

.

,

" "

,

.

( Craik ) [139]

( Jonson-Laird ) [140].

,

,

,

" "

" "

" "

[120].

,

(

),

,

( " " )

" "

" "

" "

[115]

[6].

" "

" "

( " ( )

. 17.

,

" "

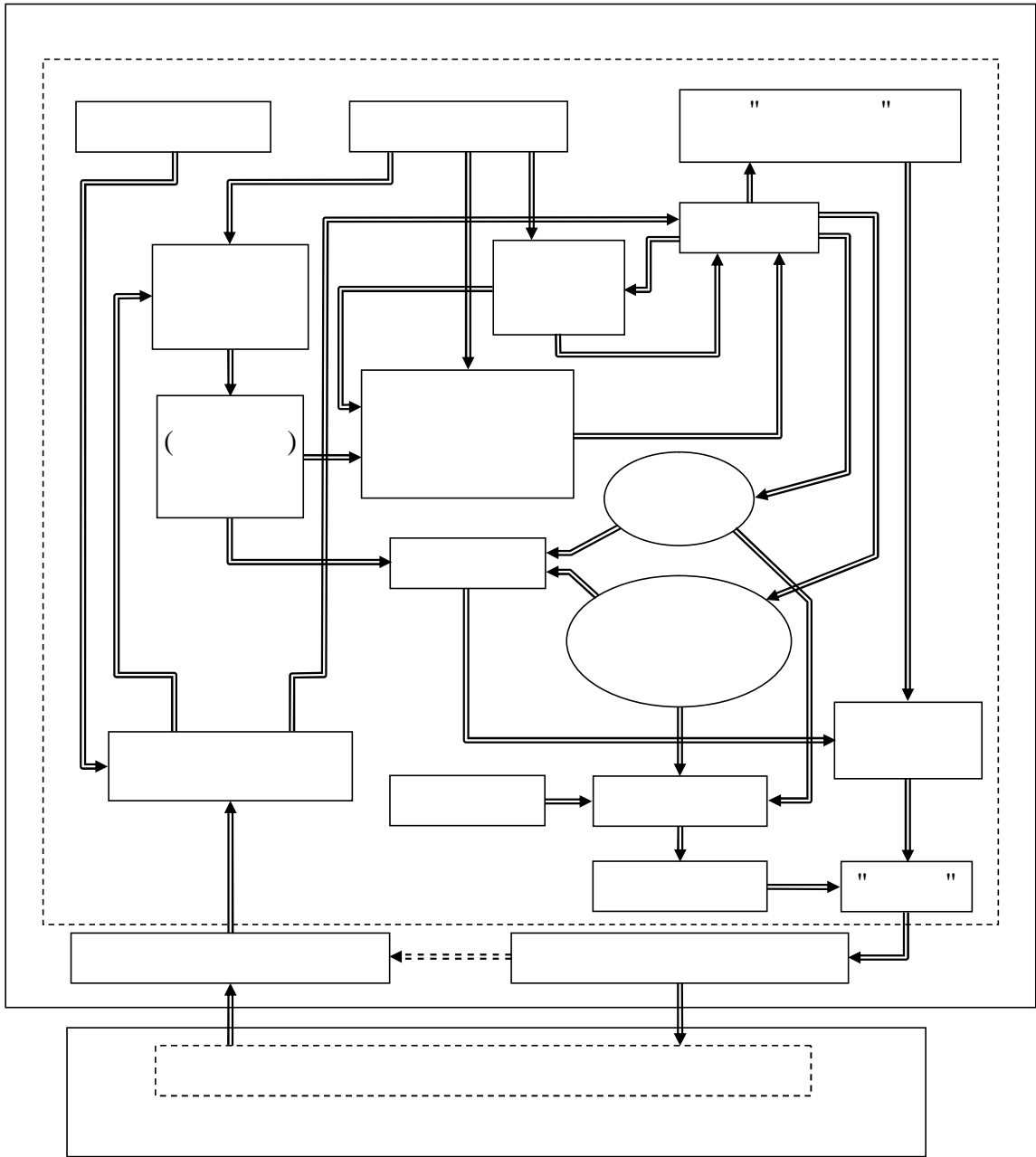

. 17. ( ) -  
 ( ) , -  
 , -  
 : ( , , -  
 ), ( , ) " " -  
 .( ) .

3.1.

,  
 . ,  
 . ,  
 , " "  
 , ( -  
 )  
 , . -  
 -  
 , , ,  
 " " .  
 " " " " -  
 .  
 . . , " , -  
 " [80, . 166]. , -  
 " "  
 ,  
 " " , ,  
 " " " " "  
 " " " " "  
 " " " " "  
 . . , " ,  
 " [2, . 22]. -  
 , . . -  
 . . .  
 " , - . . , -  
 , -

" [108, . 20]. ,

" "

" . . . , "

" , "

" " " "

" " " "

" " . "

. . . -

. 18.

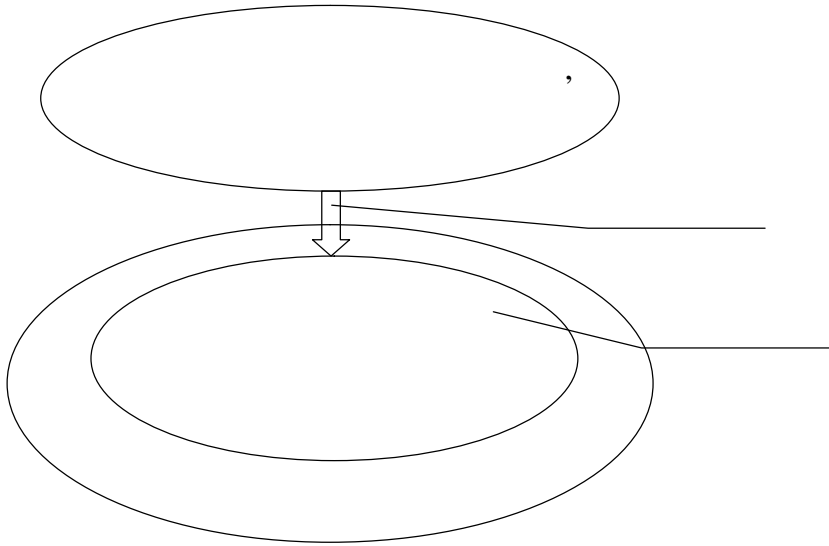

. 18.

. . . .

. . . , "

" [80, . 166]. ,

, -

" " , "

" , -

. 19.

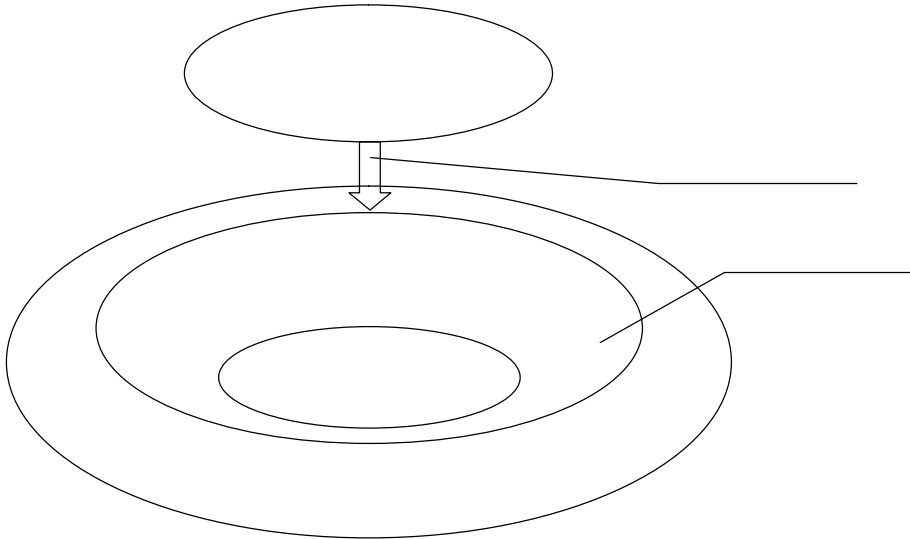

. 19. -

. . . .

. 19, , -

. . . . ,

" " " " .

, , ,

. -

, .

, , ,

. . . [85], " "

. . . [128], " " -

. . . [91].

, ,

. . . , "

, " [23, . 93]. " -

, - . . -

, -

" [2, . 21].



, , .  
 , , -  
 . , -  
 , , , -  
 . -  
 , , -  
 , , -  
 , , -  
 . -  
 . -  
 , , , -  
 , . -  
 . -  
 . -  
 , -  
 , , -  
 , -  
 . " " -  
 , -

[5] [125].  
[75],  
[3]  
?!  
(.)(1863-1914).  
"

... [73, с. 26].

... [2, . 12].

... [62, 68, 71].

( " ")

, " ",  
 ( " "),  
 . , -  
 , , -  
 . " ", -  
 , " ", -  
 - " ",  
 ,  
 ,  
 .  
 ,  
 ( ) ,  
 " "  
 . , -  
 , -  
 , " ", -  
 " " [62].  
 " ", " ", ( ,  
 " ,  
 ),  
 , " " " " " "  
 . , -  
 , -  
 .  
 ,  
 :  
 ⇒ ⇒ ⇒ .

[54],

. 20

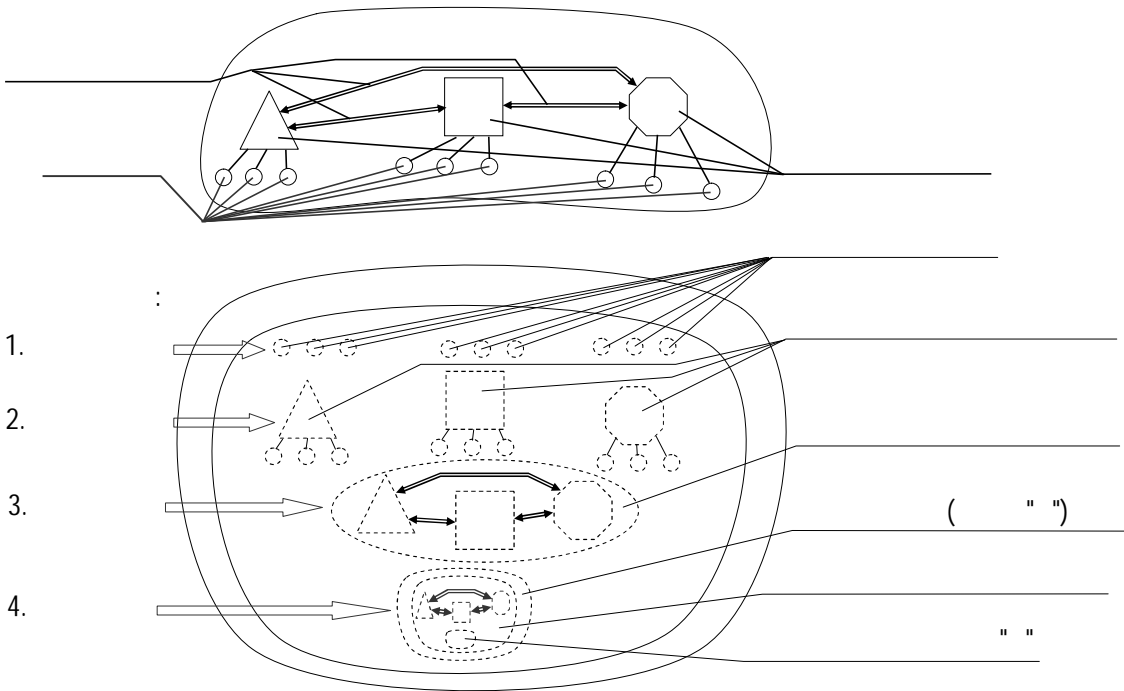

. 20.

( . . " " ).

" "

" " , " " ,

" ( / ) , ... " .

" "

. . ,

. . , " -

, -

" , . . : "

" [1, . 10-11]. -

, ,

. " , -

. . , -

,

«

/ »" [1, . 13]. . . -

, , -

. !!!

( . 2.6)

" " , " " , -

" " . ,

. . , .

" - " , " -

" " - " . , -

, " " ,

, ,

, " - " ,









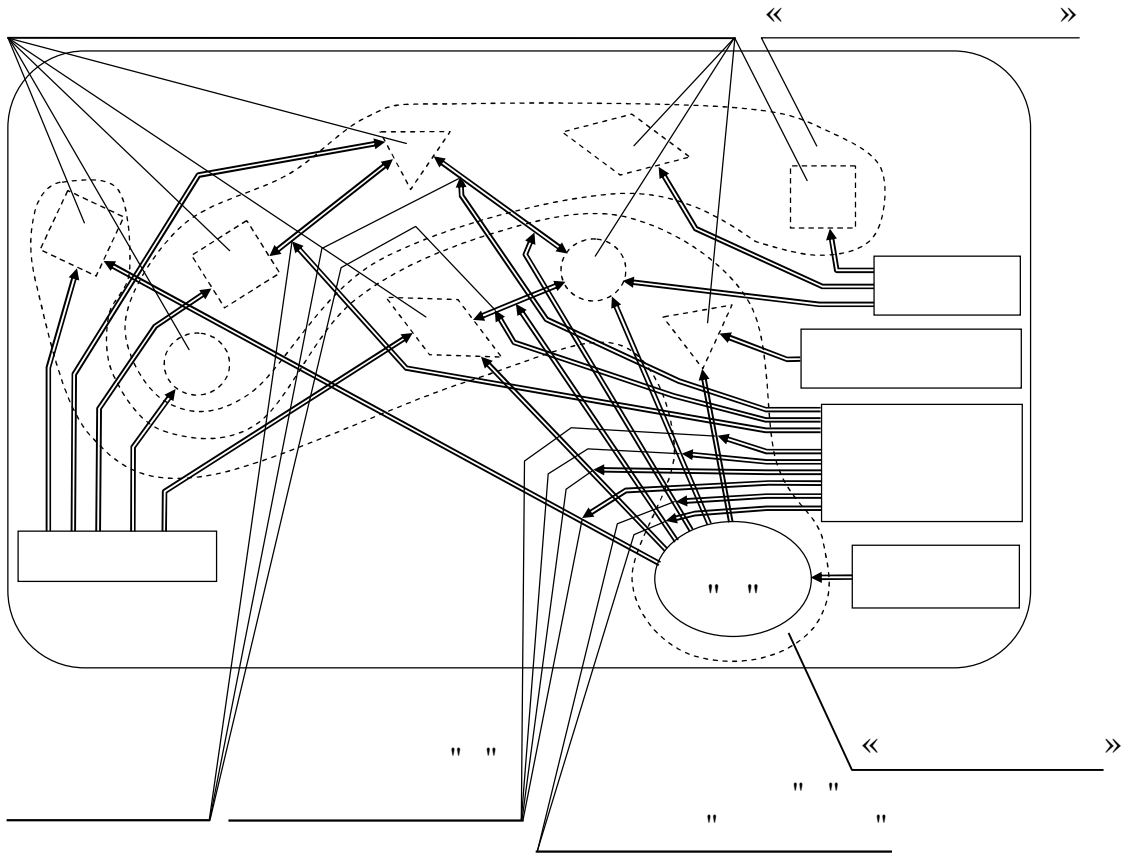

. 21.

, , , ,  
-  
-  
. " "  
:  
)  
;  
)  
. ,  
, ,  
( )  
, " " " "  
" ( ).  
, "  
" .



[138],

"

"

" . . . ,  
" ,  
"

-

-

("

")

,

"S ⇒ R".

,

,

. . .

[83, . 206],

.

-

( ) ,

-

.

-

,

-

,

-

.

,

-

,

-

.

,

,

,

,

,

,

.

,

,

-

.

,

.

,

-

.

-

.

,

,

:

1) , , ; -

2) , ; -

3) -

4) , ( -

) , -

.

-

-

,

.. , , -

.. [41], -

." « », - , -

,

" [77, . 243]. . . , "

", " , -

..." [12, . 53]. , -

, . . . , "

" [82, . 47]. , -

,

,

,

," "

( .

[100]), , -

.

, , , , " , -  
 . . , - " " , -  
 . . , - " " , -  
 . . , - ( -  
 , ) - " [77, c. 205]. -  
 , . . -  
 , , -  
 " , . . . -  
 , , -  
 , , -  
 , , -  
 , , -  
 " [ , . 206]. -  
 , , " , -  
 . . , " , . . -  
 , " -  
 " [108, . 443] :  
 " , , -  
 - " " , " [ , . 444]. -  
 , " , ? -  
 , -  
 , , -  
 . -  
 - , , -  
 . . - , -  
 , -  
 .

, " , . . . , ,  
 , " , -  
 " [107, . 115].  
 . . . , " -  
 , " " -  
 , ( ) -  
 ( )" [17, . 291]. -  
 , -  
 , " " . -  
 . -  
 . . . , " -  
 « » , , , -  
 , " [131]. , -  
 , -  
 . -  
 " " .  
 , , "interesse"  
 " " , " [134]. , -  
 ( ) - ,  
 , -  
 . " "  
 " " , , , -  
 . ,

" " " " (" ") -

,

— -

.. " — ,

[108, . 526]. " "

" ,

,

" [113]. . . — "

" [40, . 224].

, , ,

,

,

.

" " " "

" " "

.

,

(

)

).

,

,

.

—

(

),

..

" ... " [82, . 35].



[56].

. 22.

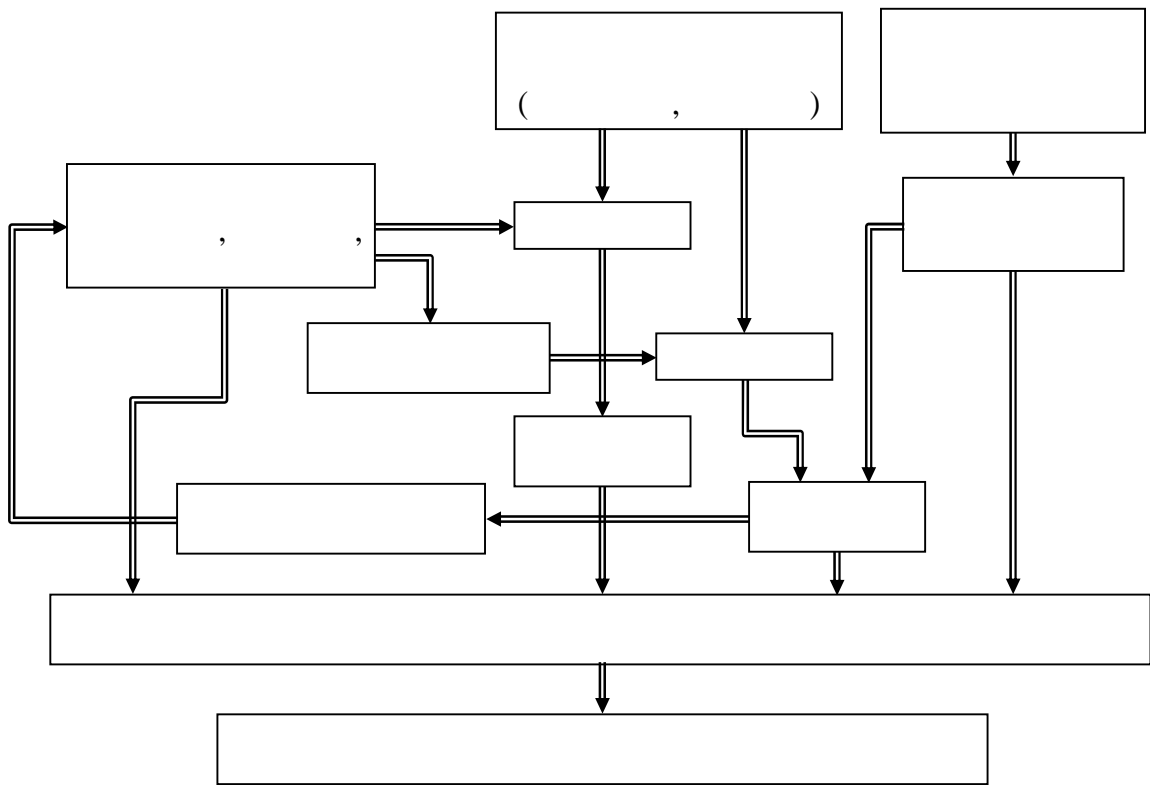

. 22.

. 23.

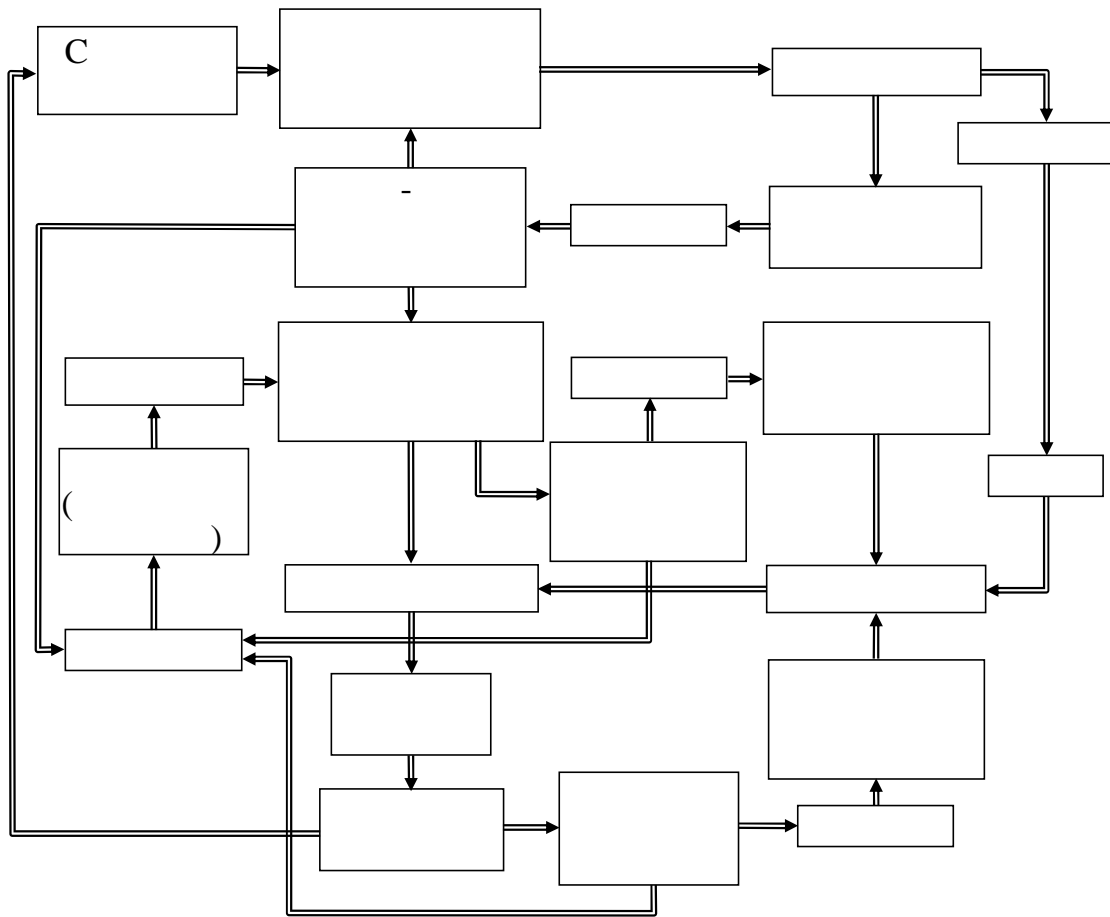

. 23.

. 23,

« »

" [83, . 205]. "

"« »

" [ , . 207]. "



, -  
 , , - ,  
 - - - ,  
 , . ,  
 - " " ,  
 , , -  
 , , , , , -  
 , , " , -  
 " , , -  
 , , -  
 , . -  
 , -  
 , , , , -  
 - " " " , -  
 , -  
 " [83, .206].  
 , -  
 , , , , -  
 , , , -  
 , -  
 , -  
 , -  
 , -  
 , , " ( - . .)  
 , , , , -  
 ,

- " [9, . 53].

( ) , ,  
. 24 , -

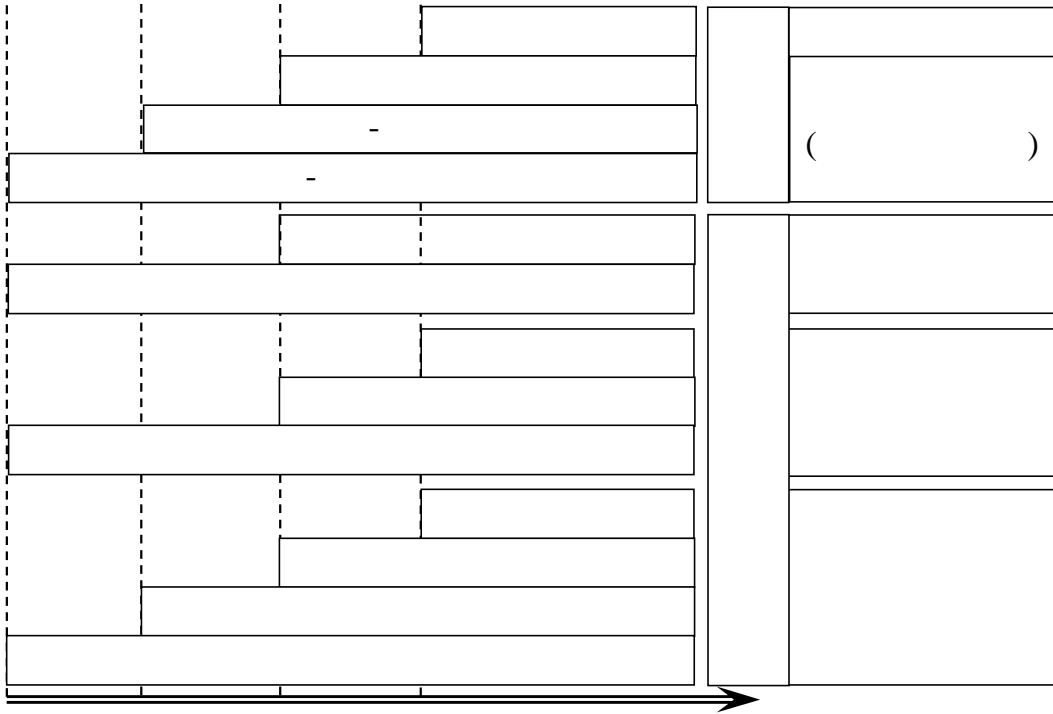

. 24. ( -  
, ) -  
( ) , ( -  
) .

### 3.3.

#### 3.3.1.

, , , -  
( ) ,

... [77],  
" [97, .62].  
" [3, .49].

[64, 68].

### 3.3.2.

[94].

" " , -  
 , -  
 ( ) , -  
 , -  
 , -  
 ( ) ( ) . -  
 : -  
 • ( ) - ( ) ;  
 • ( ) - ;  
 • (→) - ;  
 • (→) - .  
 ,  
 , - ,  
 . ,  
 (→) ( )  
 ( ) , (→) .  
 , " ,  
 ,  
 " [22, . 121].  
 ,  
 , - ,  
 , -



... " , - . . , -  
 ( - . . ) , , ,  
 " [81,  
 . 248]. . .

"  
 "  
 - "  
 " [ ] .

- ( )' - , ;
- (→)' - ;

( )' (→)' , ( )' , -  
 (→)' (→)' , (→)' ,  
 (→)' (→)' , (→)' , -

- ( ( )' )' - , ;
- ( ( )' )' - , ;
- ( (→)' )' - , .

, " -  
 " -  
 , , -  
 ( -  
 )  
 ( )' (→)' , -  
 , . -  
 -

.25.

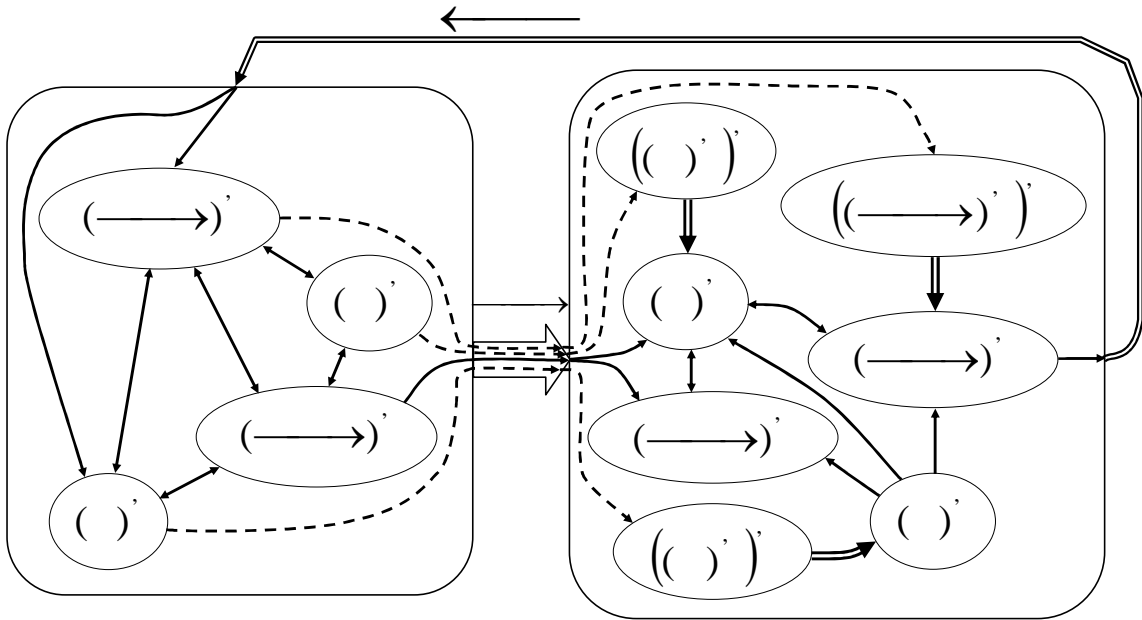

. 25.

( )  
 ( )' ( " ") , ( )' ( -  
 " " (→)' -  
 (→)' . -

. 25

, ( )' , -

" ", ( )', -  
 , " ". (( )')  
 (( )') ( )' ( )'  
 , . , -  
 , , -  
 , , -  
 (" ") ,  
 " - ".  
 " ", -  
 , , , ( , ) -  
 , , , -  
 , , , -  
 . , -  
 . -  
 " "?  
 , .  
 ( ) ( ). -  
 ( )',  
 ( i)' . ( )'  
 ( j)' . -  
 , , -  
 . -  
 (( )')', -  
 ( i)' )' . , -  
 , ( )' )'

$((j)')'$ .

“ ”  
 “ ”

$$(( )')' + (( )')' \Rightarrow ( )'.$$

( . . 25),

. 26.

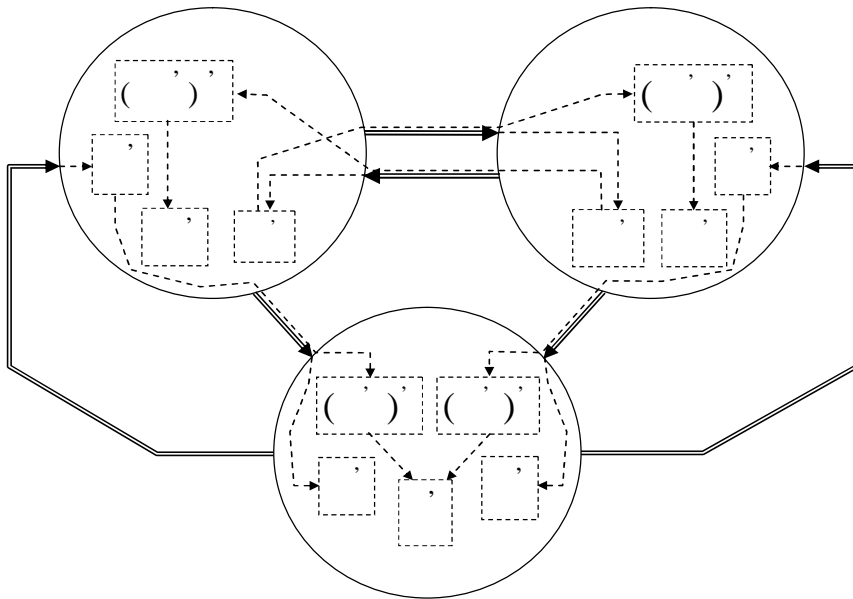

. 26.

( )  
 ( ). ( )

“ ” (( )')

— ( )

“ ”





### 3.3.3.

... , "

," [83, . 186].

" - "

» " [ , . 249]. "

« -

," -

( - ) -

" [ , . 262].

," -

," -

," -

," -

," -

," -

:" -

," -

" ?".

" ", -

," -

."





" [11, . 10].

( , , ),

( ).

( ).

" [83, . 232].

" [ , . 234].

1)

2)

3)

[82, 98].

"). ( , " -

[88].

( ) ,

( )

" - " " - " ,

.27.

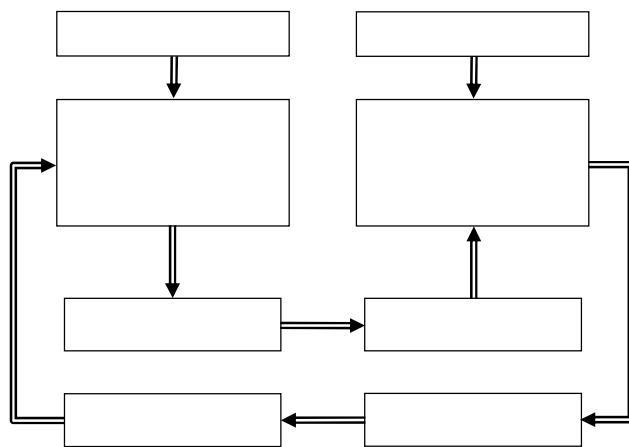

. 27.

[19, .86].

... " [16].

( ), ( ).

( ),

[47]. " ( ),

( )".

( ),

!),

, , .  
 ,  
 , , -  
 , , -  
 . " -  
 " [19, . 92]. -  
 ,  
 " " : " -  
 , -  
 : - " [ ]. -  
 ,  
 . " -  
 , « -  
 ». , - , - -  
 . « -  
 »" [19, . 95]. ,  
 " , - " [ ]. -  
 , , ( -  
 , ). -  
 , -  
 ( , ) , -  
 ( ) .  
 ,  
 " " , " " " , , -  
 , ,

, " " , -  
 " " , .  
 ( ) ( )

. 28.

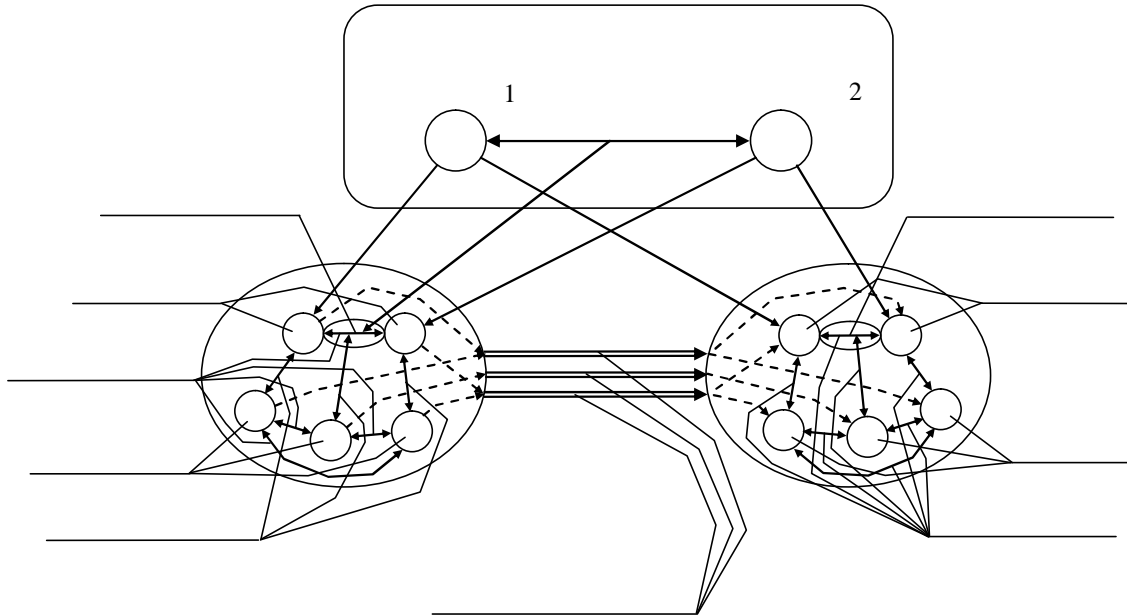

. 28.

1 2 ( -  
 ) -  
 ( ).

. . . , "  
 ( -  
 ) -  
 -  
 ,  
 " [19, . 76].

" - ,  
 , -  
 . " , « »", ,

[90]. "

" —

" " "

"

—

"

.29.

"

—

"

,

" (

"

"),

"

"

".

,

.

,



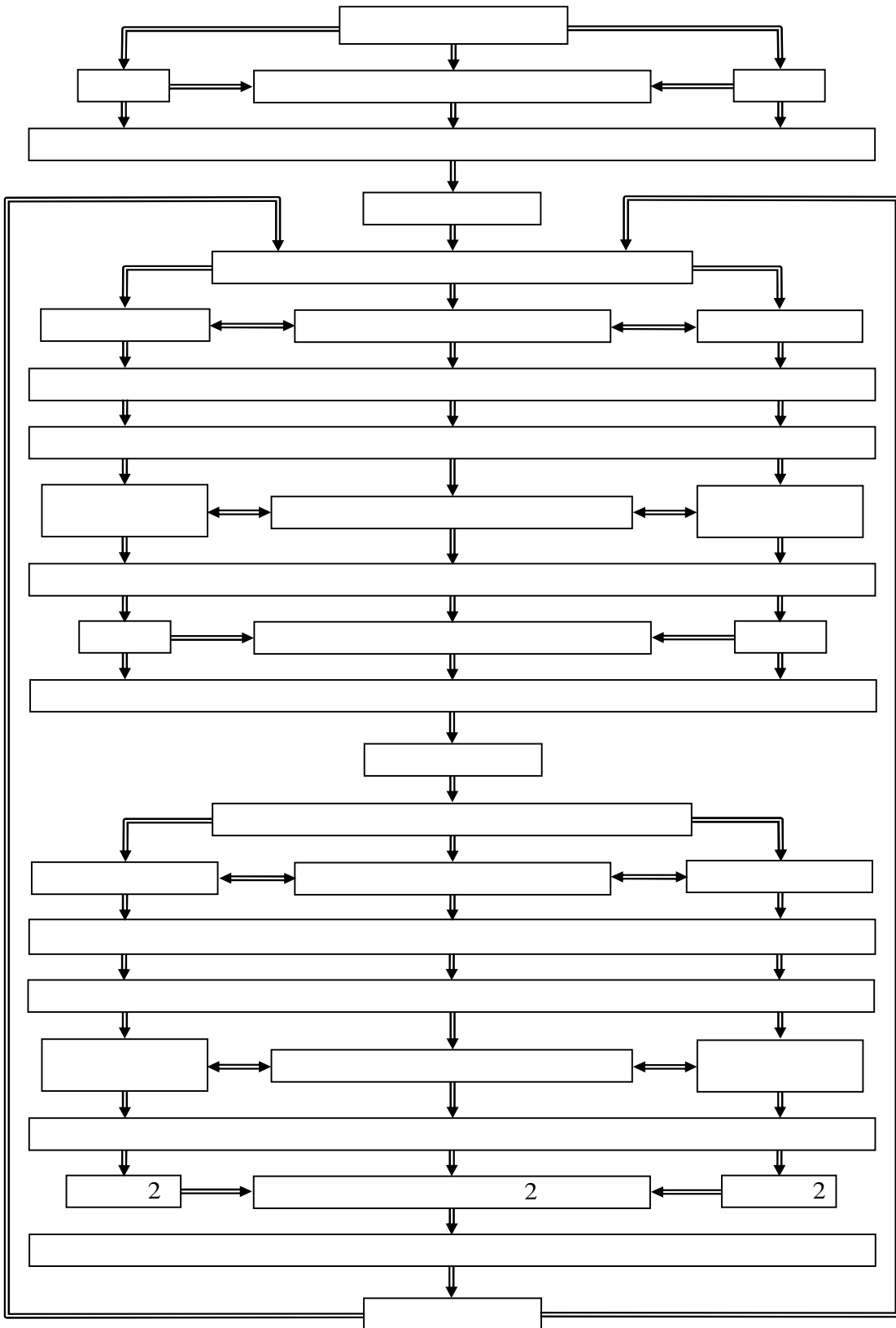

. 29.

"

-

-

"

, -  
 . -  
 , , , ,  
 , ( -  
 , - ), -  
 , , , - , -  
 [99]. -  
 , -  
 , -  
 [106]. , -  
 " " -  
 , , -  
 - -  
 . , , -  
 , -  
**3.3.4.** , -  
 , -  
 , -  
 , -  
 , , -  
 , -



( )' ( )'

( ( )' )' ( ( )' )' .

2.6,

?

, - , -  
 , , ( ) , , - , -  
 , ( → ) , -  
 , , - .  
 , , -  
 1 , -  
 → 1 → → 2 → . -  
 , -  
 , -  
 2 . → 1 → 1 -  
 1 , 2 . , -  
 2 , → 2 → , -  
 3 . -  
 , -  
 , -  
 . ? -  
 , -  
 , -  
 → 1 → 2 , , -  
 , 2 -  
 → 1 → . -  
 → 1 → , 2 , -  
 , . , -  
 ? , -  
 ? -

. 30

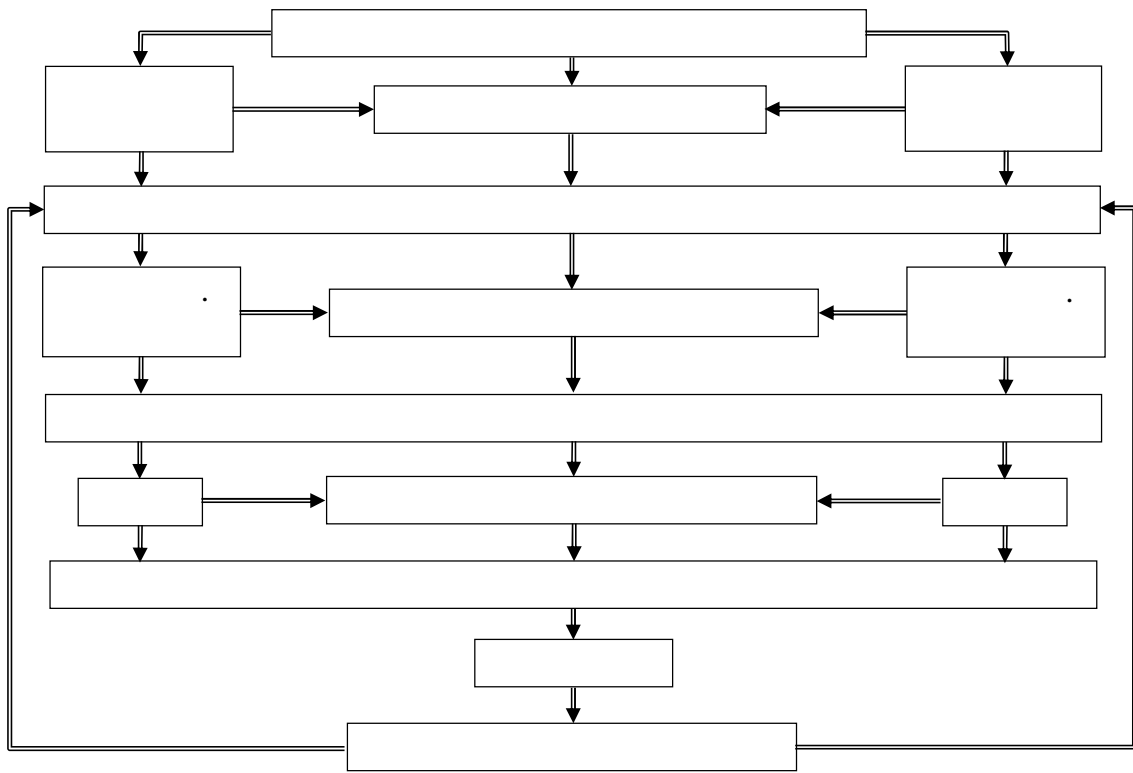

. 30.

**3.4.**

,

.

,

( ),

" "

... ,

... ,

( ) ,

...

" [99, . 337].

...

:"





,  
 .  
 :  
 ,  
 ,  
 ( → )' ( → )',  
 ,  
 ( → )' ( → )';  
 , ( )'  
 , , ,  
 ( , ( )', ( )' ( → )'  
 ( → )').  
 , , ,  
 →.  
 →,  
 , -  
 →.  
 " "  
 " ,  
 . ,  
 . ,  
 .  
 , ó ,  
 -



( . . 31).

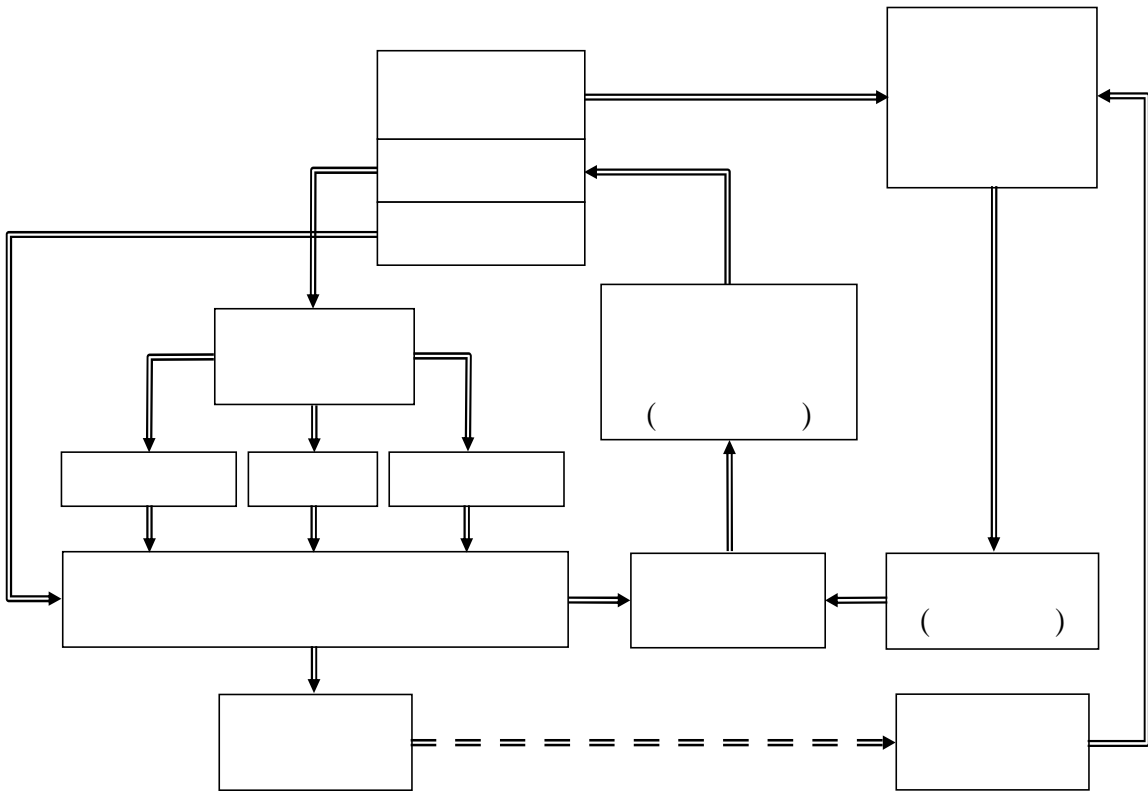

. 31.

( )

.

,

,

.

:

)

(

);

) ; -

) , -  
" " .

### 3.5.

" , , -  
" [113, . 583]. -

, , -  
, , -  
, [12, 37]. ,

, .

, .  
, -

, - ,  
, ,

, . ,  
, ,

. -

( , ), -  
,

, ( ) .

$\overline{(\ )}$  . -

$$\left(\overline{(\quad)'}\right)'$$

$$\left(\overline{(\quad)'}\right)'$$

" "

"+"

$$\left(\overline{(\quad)'}\right)' + \left(\overline{(\quad)'}\right)' \Rightarrow \left(\overline{(\quad)'}\right)'$$

→ ,

(→)' . - ,

$$\overline{\left(\overline{(\rightarrow)'}\right)'}$$

$$\left(\overline{(\rightarrow)'}\right)'$$

→

$$\left(\overline{\left(\overline{(\rightarrow)'}\right)'}\right)'$$

$$\left(\overline{\left(\overline{(\rightarrow)'}\right)'}\right)'$$

( " ") ,

[38].

[50].

[36, 50].

. 32).

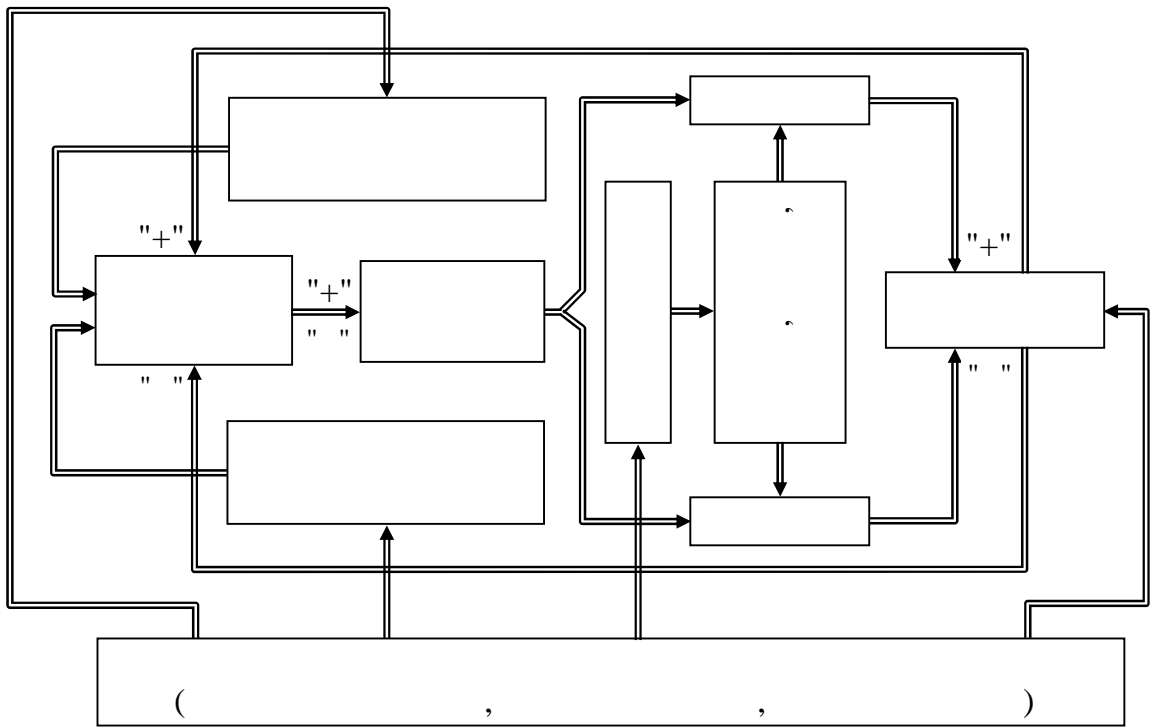

. 32.



3.6.

, ,  
 , ,  
 , .  
 , ,  
 , ,  
 . ,  
 , ,  
 , " " .  
 , . . .  
 " . . . —  
 , ,  
 , , , ,  
 . , ,  
 .

" [108, . 489].

. . . ,  
 , "  
 " [132, . 61].



" ( . . . )  
 , [ , . 62].  
 , -  
 ,  
 .  
 -  
 -  
 ,  
 -  
 . . .  
 ,  
 -  
 -  
 " [132,  
 . 20].  
 ,  
 ,  
 ,  
 .  
 -  
 -  
 ,  
 -  
 ,  
 -  
 .  
 -  
 -  
 ,  
 -  
 ,  
 -  
 .  
 -  
 ,  
 -  
 " , " " ,  
 " ,  
 . . .  
 . " .  
 -  
 ,  
 -  
 ,  
 ,  
 " ( .  
 [132, . 16)].

... , " -  
-  
...  
-  
,  
,  
" [132, .62]. -  
" "-

. -  
-  
,  
.  
-  
,  
" - " " " " -  
-  
" " " " -  
-  
-

,  
-  
-  
.  
-  
.

**3.7.**

" " -  
.  
,  
" " " " -  
.  
, : " « »

« » , -

«mores» ( , ) -

« »" [136, . 98].

" "

" " " " " " -"

" " - , .

, .

, .

, "

, ,

- ,

-

" [120].

-

-

, -

, "

" : "

, :

" [136, . 89].

" "

, ,

" " , "

" " - " [124, .

306]. " " " "

" [ ].

?

, . ,

, -

, -

« » - « »" [124, . 315].

[51],





... " ( , -  
 ) " ... " ( , -  
 , ) .

, ( , -  
 ),

" " " " ,  
 .  
 ,

. , , , -  
 , , , ,

" " " " ,  
 , , , ,

. " " . , -  
 , , , , ,

" " " " , -  
 , , , , ,

.  
 , , , , -  
 , , , , -  
 . -  
 -  
 .  
 " " ,  
 . , - " -  
 " , " " -  
 , .  
 ,  
 - - , -  
 , . -  
 ,  
 , , , , -  
 , , , , -  
 , , , , . -  
 , , , , -  
 ( , , ) , " " .  
 . " " -  
 " " ,  
 , , , , .  
 , , , , -  
 - - , -  
 , , , , -  
 .





, , ; -  
:  
, , -  
, . -

.33.

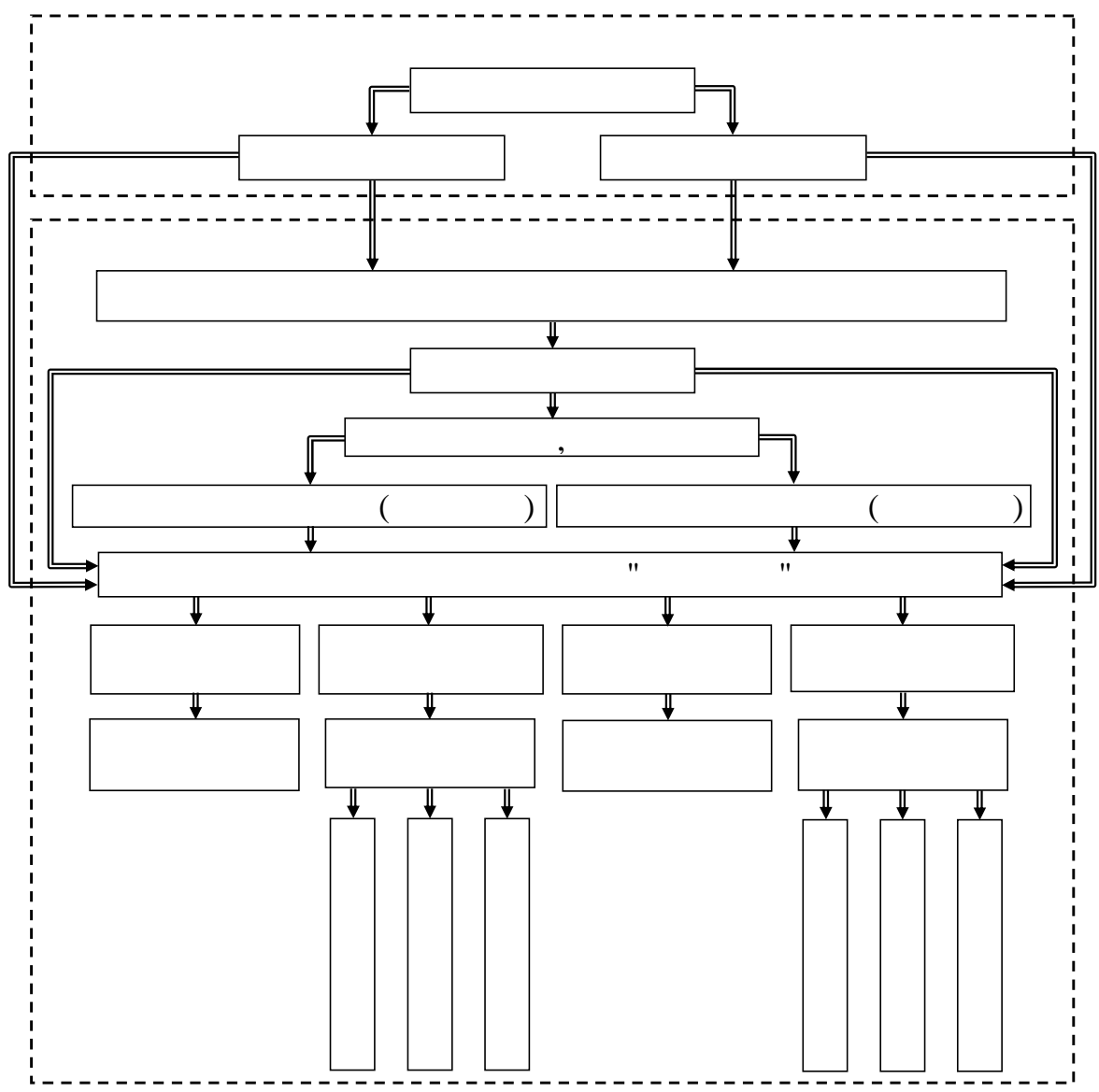

.33.

, , -









1)

, -

;

2)

;

3)

.

.

,

,

.

" " ,

-

,

,

.

,

-

-

.

,

,

-

,

,

,

,

,

.

-

,

.

-

.

,

,

-

.

,

-

-

,

,

"

,

,

"

.

, ,  
 ,  
 " " .  
 ) , ( .  
 . ,  
 , ,  
 → ,  $\left( \overline{\left( \rightarrow \right)} \right)^+$  .  
 $\left( \overline{\left( \rightarrow \right)} \right)^-$  ,  
 .







. -  
 . -  
 , -  
 . -  
 , -  
 . -  
 , , , -  
 . -  
 , -  
 , -  
 : ⇒ -  
 ⇒ ⇒ ⇒ . -  
 , -  
 , -  
 , -  
 ( ) -  
 " " , -  
 , -  
 , -  
 , " " -  
 , -  
 " " , " " , -  
 , -





1. . . . . - :  
" - ", 2007.
2. . . . . :  
. - . :  
; : " ", 2004.
3. . . . . -  
. - . :  
" ", 2003.
4. . . . . // -  
. - : , 1969. -  
. 109-139.
5. . . . . // -  
. - 1970. - . 1. - 1. - . 19-54.
6. . . . . -  
// . - . :  
, 1973. - . 5-61.
7. . . . . -  
// . - . :  
. - . : , 1978. - . 7-26.
8. . . . . -  
// . - 1981. - . 2. -  
2. - . 8-18.
9. . . . . - . : , 1947.
10. . . . . - . : , 1991.
11. . . . . - . : " -  
"; : " ", 1996.
12. . . . . / .  
. . . . . -  
"; : " ", 1997.
13. / . . . . -  
, . . . . - . : , 2003.

14. . . . -  
// . - 1982. - 2. - . 28-40.
15. . . . : -  
. - .: ; Per Se, 2000.
16. . . . . - .: -  
, 1968.
17. . . . // . -  
. - .: , 2004. - . 285-302.
18. . . . , , // .  
.: 6 . . 1: . - .: -  
, 1982. - . 132-133.
19. . . . // .  
.: 6 . . 3: . - .: , 1983. -  
. 41-90.
20. . . . : -  
. . - .: .  
. 2001.
21. . . . . - .: ,  
2000.
22. . . . . -  
.: , 1988.
23. . . . .  
. - .: - . - . - , 1997.
24. . . . . -  
. - .: " ", " ", 2002.
25. . . . , -  
// . . . . 2- .  
. 1. - ., 1963.
26. . . .  
/ . . - ., 1957.
27. . . . // .: 8 . - .; ., 1939.

28. . . . . 1.-
- // / . . . . , . . . . . 1.-
- ∴ ,1997.- . 98-105.
29. . . . . - ∴ ,1991.
30. . . . . // . -
1968. - 8. - . 125-136.
31. . . . . " -
- " // . - 1976. - 11. - . 41-54.
32. . . . . , , . - ∴
- ,1980.
33. . . . . :
- // . - 1990. - 11. - 6. - . 3-15.
34. . . . .
- // , 26-27 2002 . -
- ∴ - . . . . , 2002. -
- . 110-119.
35. . . . . :
- // . - 2003. - 4. - . 22-26.
36. . . . . - ∴
- " ,1993.
37. . . . . . . . . . .
- . - . ,1989.
38. . . . . - ∴ -
- ,1986.
39. . , / . . . .
- . - ∴ ACT , 2005.
40. . . . . - ∴ -
- , , 2008.
41. . . . . -
- // . . . . : 2- .
- . I - ∴ , 1983. - . 8-16.
42. . . . . // .
- : , -
- . - ∴ " , 2004. -
- . 11-15.



43. . . , " " : ? / . . . . . - ∴ , 2006.
44. . . : // . . . . . - 1996. - . 46. - . 2. - . 241-252.
45. . . // - : / . . . . . - ∴ , 2003. - . 200-217.
46. . . - ∴ " ", 2000.
47. : / . . . . . - ∴ ; , 2002.
48. . // . . . . . / . . . . . , . . . - ∴ - . - , 1981. - . 235-249.
49. . . : . - ∴ - , 1999.
50. . . // . . . . . - . - , 2001. - . 3. - . 1. - . 238-242.
51. . . . - ∴ : , 1984.
52. . . // : - / - , , 15-17 2000 . - , 2000. - . 39-43.
53. . . - // - / . . . . . , 29-31 2001 . - : , 2001. - . 24-27.

54. . . // -  
: 3- -  
. 25-28 2003 : 8 .- .: -  
.- . - , 2003. - .IV. - . 383-387.
55. . . -  
. . // . . -  
: . - : - , 2003. -  
. 20-24.
56. . . -  
// .-2003.- 1.- . 131-140.
57. . . . .  
" " // . . :  
- . , ,  
29-30 2005 . 3. 1. - :  
, 2005. - . 51-58.
58. . .  
.- : - , 2005.
59. . . "  
" // .-2006.- 5.- . 186-194.
60. . . -  
// : , -  
: . . . - .  
. 23 2003 .- : " ", 2003. - . 137-140.
61. . . -  
/  
: / . . . -  
.- : , 2007. - . 7-21.
62. . . , -  
// : . -  
I , , 29 - 1 2007 .-  
: - " - " , 2007. - . 61-63.
63. . . " "  
// .-2008.- 5.- 1.- . 9-22.

64. . . . -  
 //  
 ( . . . . . ) . 2 (50). - .: , 2008. -  
 . 85-88.
65. . . . - 2008. - 2. -  
 // . . . . .
- . 5-19.
66. . . . - 2009. - 3 (10). - . 47-60.  
 // . . . . .
67. . . . , ,  
 // / 3- -  
 - , , 14-15  
 2009 .; . . . , . . . . - : -  
 , 2009. - . 47-54.
68. . . . :  
 // : / . . . . -  
 . - : - . . . . - , 2009. - . 178-186.
69. . . . : -  
 // . - 2009. -  
 4 (11). - . 78-89.
70. . . . ,  
 // XXI :  
 . . . . /  
 , , 10-13 , 2009 . . 1. - .; :  
 . . . . , 2009. - . 166-171.
71. . . . -  
 // . - 2010. - 36. -  
 . 20-26.
72. . . . -  
 , 1986.
73. . -  
 // 1991-2005. : 2 . . 2. - .: -  
 " , 2006. - . 9-46.
74. . . . - .: , 1911.

75. . . . . - ∴ -  
, 1964.
76. . . . . : . -  
∴ , 2002.
77. . . . . // -  
: 2- . . I. - ∴ ,  
1983. - . 143-279.
78. . . . . // .  
. 14. . - 1993. - 2. - . 3-14.
79. . . . . //  
: 2- . . II. - ∴ , 1983. -  
. 94-231.
80. . . . . - ∴ ,  
2000.
81. . . . . , . - ∴ -  
" "; :  
" ", 1997.
82. . . . . - ∴ -  
, 1986.
83. . . . .  
. - ∴ , 1984.
84. . . . . -  
∴ - , 1975.
85. . . . . - ∴ , 2001.
86. . . . . // . , -  
. . . 6. - ∴ . - , 1957. -  
. 139-147.
87. . . . . - ∴ . 1982.
88. . . . . ( ) . -  
∴ - , 1957.
89. . . . . // ∴  
: . - ∴ - , 1994. - . 227-237.
90. . . . . : ,  
, : . - 4- . , . - ∴  
" , 1999.

91. . . . – ∴ , - , 2008.
92. . . . : . [ ] . – URL: <http://www.nounivers.narod.ru/pub/guilt.htm> ( : 22.01.2010).
93. . . . // - . – ∴ . - , 1997. – . 278-283.
94. . . . : , , . – ∴ , 1995.
95. . . . : . - . – ∴ , 1991.
96. . . . // - " - " , 2004.
97. - . . . : . – C ∴ , 2003.
98. . e ! . – ∴ - " +", 1995.
99. . . . , . – 2- . – ∴ " "; , 2001.
100. . . . " " , 2003.
101. . . . – ∴ , 2004.
102. . . . - " " . 2005. [ ] . – URL: [http://www.chronos.msu.ru/RREPORTS/pimenov\\_ne.htm](http://www.chronos.msu.ru/RREPORTS/pimenov_ne.htm) ( : 16.01.2010).
103. . . . – ∴ , 1972.
104. . . . / . . – ∴ , 1975.

105. . [ ]. – URL: <http://www.onlinedics.ru/slovar/psychology.html> ( : 16.01.2010).
106. . – .: " - ", 2003.
107. ., ., . : . – .: , 2000.
108. . . . – .: , 2001.
109. . . . – .: - , 1939.
110. . . // - . – 1982. – 4. – . 149-159.
111. . . . – .: - , 1990.
112. . . . – .: . , 1961.
113. / . . . . – : , 1997.
114. . . . . – .: . - , 2005.
115. . . // . – 1986. – 4. – С. 128-136.
116. . . // . . 45. - . – ., 1953.
117. . . // . – 2006. – . 1. – . 1. – . 85-99.
118. // . – 1974. – 1. – . 40-48.

119. . . // XXI :  
/ . . . . - .: , 2003. -  
. 291-353.
120. . // -  
. . 1.- ., 1955.
121. . . , , .- .: , 1972.
122. . / . .  
. , . . - .: , 1999.
123. / . . . , . . -  
. - .: , 1997.
124. / . . . . . -  
: " " , 2003.
125. . . //  
. - .- .: . . . - , 1926. - . 58-63.
126. . . . - .: .  
, 1985.
127. . . -  
// . - 2004. - 2. -  
. 104-118.
128. . . -  
// . - 2007. - 3. - . 3-15.
129. . .  
. . - .: , 1982.
130. . .  
. - .: , 1982.
131. . . " "  
// -  
" " . - 2004. [ . ] . - URL:  
<http://www.eidos.ru/journal/2004/0205.htm> ( : 16.01.2010).
132. . . . - .: , 1978.
133. . . . 6- . - .: ,  
1934.

134. . [ ]. – URL: <http://www.onlinedics.ru/slovar/fasmer.html> ( : 16.01.2010).
135. . / . . . 2001. [ - ]. – URL: <http://www.jungland.ru/node/1592> ( - : 16.01.2010).
136. . // : / . . , . , . , . ; . . . , . . . . – .: , 1995. – . 80-99.
137. . . . – .: , 1996.
138. Chalmers, D.J. The conscious mind: in search of a fundamental theory. – N.Y.: Oxford University Press, 1996.
139. Craik, K. The Nature of Explanation. – Cambridge: Cambridge University Press, 1943.
140. Jonson-Laird, P.N. Mental models: Towards the cognitive science of language, and consciousness. – Cambridge: Cambridge University Press, 1983.
141. Hebb, D. O. The organization of behavior: A neurophysiological theory. – New York: Wiley, 1949.
142. Hooker, C.A. Information-processing Approach to the Brain-Mind and its Philosophical Remitications //Philosophy and Phenomenological Research. – 1975. – Vol. 36. – 1.
143. Kohlberg, L.E. The psychology of moral development: The nature and validity of moral stages. Vol. 2. – San Francisco: Harper & Row, 1984.



,

,

,

«Times New Roman». \_\_\_\_\_06.2010 .  
60 84 1/16. . . . 11,6  
\_\_\_\_\_ . 936

---

« - -XXI »  
420073, . . . , 88, . 19  
.: (843) 2-945-725; ./ : (843) 295-14-48

---

« - -XXI »